

Classical Control

Topics covered:

Modeling. ODEs. Linearization.
Laplace transform. Transfer functions.
Block diagrams. Mason's Rule.
Time response specifications.
Effects of zeros and poles.
Stability via Routh-Hurwitz.
Feedback: Disturbance rejection, Sensitivity, Steady-state tracking.
PID controllers and Ziegler-Nichols tuning procedure.
Actuator saturation and integrator wind-up.

Root locus.
Frequency response--Bode and Nyquist diagrams.
Stability Margins.
Design of dynamic compensators.

Classical Control

Text: *Feedback Control of Dynamic Systems*,
4th Edition, G.F. Franklin, J.D. Powell and A. Emami-Naeini
Prentice Hall 2002.

What is control?

For any analysis we need a mathematical MODEL of the system

Model → Relation between gas pedal and speed:

10 mph change in speed per each degree rotation of gas pedal

Disturbance → Slope of road:

5 mph change in speed per each degree change of slope

Block diagram for the cruise control plant:

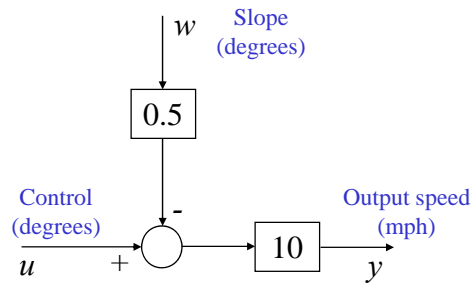

$$y = 10(u - 0.5w)$$

What is control?

Open-loop cruise control:

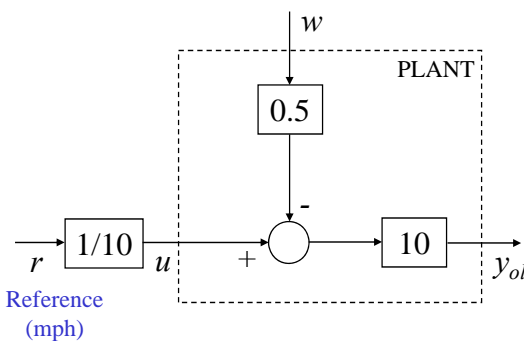

$$u = \frac{r}{10}$$

$$y_{ol} = 10(u - 0.5w)$$

$$= 10\left(\frac{r}{10} - 0.5w\right)$$

$$= r - 5w$$

$$e_{ol} = r - y_{ol} = 5w$$

$$e_{ol}[\%] = \frac{r - y_{ol}}{r} = 500 \frac{w}{r}$$

$$r = 65, w = 0 \Rightarrow e_{ol} = 0$$

$$r = 65, w = 1 \Rightarrow e_{ol} = 5\text{mph}, e_{ol} = 7.69\%$$

OK when:

- 1- Plant is known exactly
- 2- There is no disturbance

What is control?

Closed-loop cruise control:

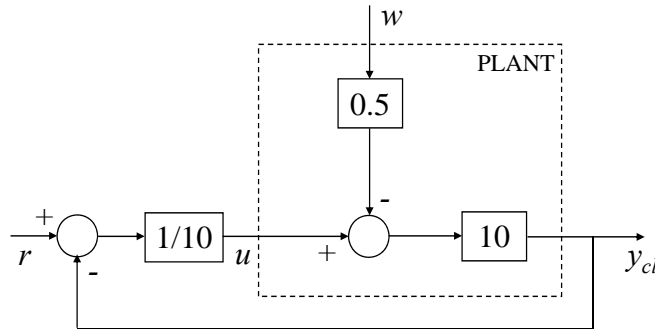

$$u = 20(r - y_{cl})$$

$$y_{cl} = 10(u - 0.5w)$$

$$= \frac{200}{201}r - \frac{5}{201}w$$

$$e_{cl} = r - y_{cl} = \frac{1}{201}r + \frac{5}{201}w$$

$$e_{cl}[\%] = \frac{r - y_{cl}}{r} = \frac{1}{201} + \frac{5}{201} \frac{w}{r}$$

$$r = 65, w = 0 \Rightarrow e_{cl} = \frac{1}{201}\% = 0.5\%$$

$$r = 65, w = 1 \Rightarrow e_{cl} = \frac{1}{201} + \frac{5}{201} \frac{5}{65} = 0.69\%$$

Classical Control – Prof. Eugenio Schuster – Lehigh University

5

What is control?

Feedback control can help:

- reference following (tracking)
- disturbance rejection
- changing dynamic behavior

LARGE gain is essential but there is a STABILITY limit

“The issue of how to get the gain as large as possible to reduce the errors due to disturbances and uncertainties without making the system become unstable is what much of feedback control design is all about”

First step in this design process: DYNAMIC MODEL

Classical Control – Prof. Eugenio Schuster – Lehigh University

6

Dynamic Models

MECHANICAL SYSTEMS:

$$F = ma \quad \text{Newton's law}$$



$$m\ddot{x} = u - b\dot{x}$$

$$v = \dot{x} \quad \text{velocity}$$

$$a = \dot{v} = \ddot{x} \quad \text{acceleration}$$

$$\dot{v} + \frac{b}{m}v = \frac{u}{m} \xrightarrow{v=V_o e^{st}, u=U_o e^{st}} \frac{V_o}{U_o} = \frac{1/m}{s + b/m} \quad \text{Transfer Function}$$

$\frac{d}{dt} \rightarrow s$

Dynamic Models

MECHANICAL SYSTEMS:

$$F = I\alpha \quad \text{Newton's law}$$

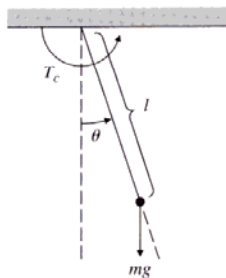

$$ml^2\ddot{\theta} = -lmg \sin \theta + T_c$$

$$\omega = \dot{\theta} \quad \text{angular velocity}$$

$$\alpha = \dot{\omega} = \ddot{\theta} \quad \text{angular acceleration}$$

$$I = ml^2 \quad \text{moment of inertia}$$

$$\ddot{\theta} + \frac{g}{l} \sin \theta = \frac{T_c}{ml^2} \xrightarrow{\sin \theta \approx \theta} \ddot{\theta} + \frac{g}{l} \theta = \frac{T_c}{ml^2} \quad \text{Linearization}$$

Dynamic Models

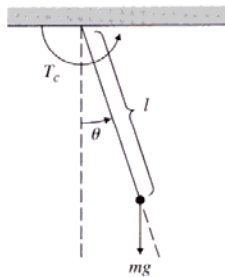

$$\ddot{\theta} + \frac{g}{l}\theta = \frac{T_c}{ml^2}$$

Reduce to first order equations:

$$\begin{aligned} x_1 &= \theta & \dot{x}_1 &= x_2 \\ x_2 &= \dot{\theta} & \dot{x}_2 &= -\frac{g}{l}x_1 + \frac{T_c}{ml^2} \end{aligned}$$

$$x \equiv \begin{bmatrix} x_1 \\ x_2 \end{bmatrix}, u \equiv \frac{T_c}{ml^2} \Rightarrow \dot{x} = \begin{bmatrix} 0 & 1 \\ -\frac{g}{l} & 0 \end{bmatrix} x + \begin{bmatrix} 0 \\ 1 \end{bmatrix} u$$

State Variable Representation

General case: $\dot{x} = Fx + Gu$
 $y = Hx + Ju$

Dynamic Models

ELECTRICAL SYSTEMS:

Kirchoff's Current Law (KCL):

The algebraic sum of currents entering a node is zero at every instant

Kirchoff's Voltage Law (KVL)

The algebraic sum of voltages around a loop is zero at every instant

Resistors:

$$v_R(t) = Ri_R(t) \Leftrightarrow i_R(t) = Gv_R(t)$$

Capacitors:

$$i_C(t) = C \frac{dv_C(t)}{dt} \Leftrightarrow v_C(t) = \frac{1}{C} \int_0^t i_C(\tau) d\tau + v_C(0)$$

Inductors:

$$v_L(t) = L \frac{di_L(t)}{dt} \Leftrightarrow i_L(t) = \frac{1}{L} \int_0^t v_L(\tau) d\tau + i_L(0)$$

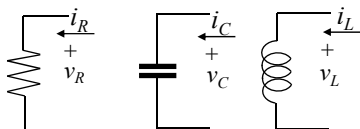

Dynamic Models

ELECTRICAL SYSTEMS:

OP AMP:

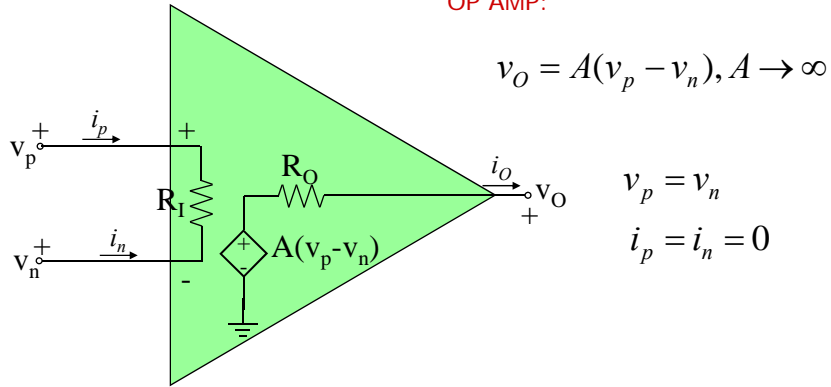

To work in the linear mode we need FEEDBACK!!!

Dynamic Models

ELECTRICAL SYSTEMS:

KCL:

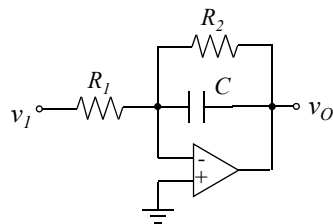

$$\frac{dv_O}{dt} = \frac{1}{R_2 C} v_O - \frac{1}{R_1 C} v_I$$

$$R_2 = \infty \text{ (OC)} \Rightarrow v_O(t) = v_O(0) - \frac{1}{R_1 C} \int_0^t v_I(\mu) d\mu$$

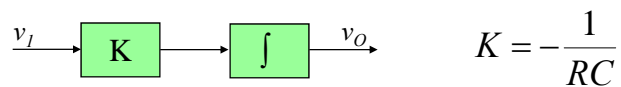

Inverting integrator

Dynamic Models

ELECTRO-MECHANICAL SYSTEMS: DC Motor

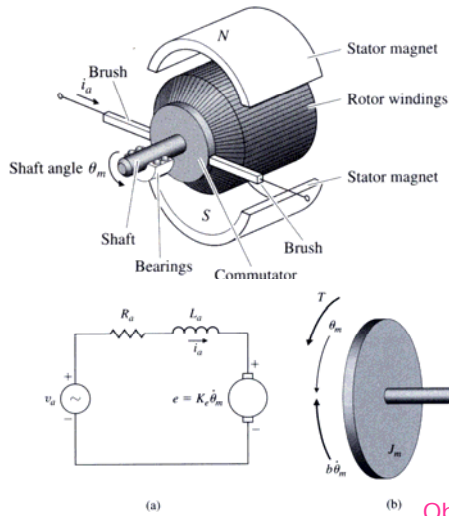

torque armature current

$$T = K_t i_a$$

$$e = K_e \dot{\theta}_m$$

emf shaft velocity

$$J_m \ddot{\theta}_m = -b \dot{\theta}_m + T$$

$$-v_a + R_a i_a + L \frac{di_a}{dt} + e = 0$$

Obtain the State Variable Representation

Dynamic Models

HEAT-FLOW:

Heat Flow Temperature Difference

$$q = \frac{1}{R} (T_1 - T_2)$$

$$\dot{T} = \frac{1}{C} q$$

Thermal capacitance Thermal resistance

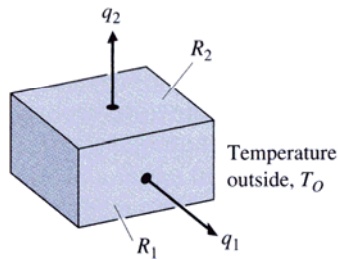

$$\dot{T}_I = \frac{1}{C_I} \left(\frac{1}{R_1} + \frac{1}{R_2} \right) (T_o - T_I)$$

Dynamic Models

FLUID-FLOW:

Mass rate

Mass Conservation law

$$\dot{m} = w_{in} - w_{out}$$

Inlet mass flow

Outlet mass flow

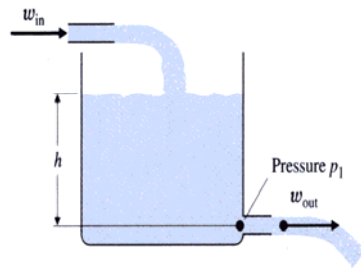

$$\dot{m} = \rho A \dot{h} \Rightarrow \dot{h} = \frac{1}{\rho A} (w_{in} - w_{out})$$

A: area of the tank
 ρ : density of fluid
 h: height of water

Linearization

Dynamic System: $\dot{x} = f(x, u)$

$$0 = f(x_o, u_o) \quad \text{Equilibrium}$$

Denote $\delta x = x - x_o, \delta u = u - u_o$

$$\delta \dot{x} = f(x_o + \delta x, u_o + \delta u)$$

Taylor Expansion

$$\delta \dot{x} \approx f(x_o, u_o) + \left. \frac{\partial f}{\partial x} \right|_{x_o, u_o} \delta x + \left. \frac{\partial f}{\partial u} \right|_{x_o, u_o} \delta u$$

$$F \equiv \left. \frac{\partial f}{\partial x} \right|_{x_o, u_o}, G \equiv \left. \frac{\partial f}{\partial u} \right|_{x_o, u_o} \Rightarrow \delta \dot{x} \approx F \delta x + G \delta u$$

Linearization

$$\delta \dot{x} \approx F \delta x + G \delta u$$

$$F \equiv \left. \frac{\partial f}{\partial x} \right|_{x_o, u_o} = \begin{bmatrix} \frac{\partial f_1}{\partial x_1} & \dots & \frac{\partial f_1}{\partial x_n} \\ \vdots & & \vdots \\ \frac{\partial f_n}{\partial x_1} & \dots & \frac{\partial f_n}{\partial x_n} \end{bmatrix}_{x_o, u_o}, \quad G \equiv \left. \frac{\partial f}{\partial u} \right|_{x_o, u_o} = \begin{bmatrix} \frac{\partial f_1}{\partial u_1} & \dots & \frac{\partial f_1}{\partial u_m} \\ \vdots & & \vdots \\ \frac{\partial f_n}{\partial u_1} & \dots & \frac{\partial f_n}{\partial u_m} \end{bmatrix}_{x_o, u_o}$$

Example: Pendulum with friction $\ddot{\theta} + \frac{k}{m} \dot{\theta} + \frac{g}{l} \sin \theta = 0$

$$\dot{x} = \begin{bmatrix} 0 & 1 \\ -\frac{g}{l} \cos x_1 & -\frac{k}{m} \end{bmatrix}_{x_o} x$$

Laplace Transform

- **Function $f(t)$ of time**

- Piecewise continuous and exponential order $|f(t)| < Ke^{bt}$

$$F(s) = \int_{0^-}^{\infty} f(t) e^{-st} dt \quad \mathcal{L}^{-1}[F(s)] = f(t) = \frac{1}{2\pi j} \int_{\alpha-j\infty}^{\alpha+j\infty} F(s) e^{st} ds$$

- 0- limit is used to capture transients and discontinuities at $t=0$

- s is a complex variable ($\sigma + j\omega$)

- There is a need to worry about regions of convergence of the integral

- Units of s are $\text{sec}^{-1} = \text{Hz}$

- A frequency

- If $f(t)$ is volts (amps) then $F(s)$ is volt-seconds (amp-seconds)

Laplace transform examples

- **Step function – unit Heavyside Function**

- After Oliver Heavyside (1850-1925)

$$u(t) = \begin{cases} 0, & \text{for } t < 0 \\ 1, & \text{for } t \geq 0 \end{cases}$$

$$F(s) = \int_{0-}^{\infty} u(t)e^{-st} dt = \int_{0-}^{\infty} e^{-st} dt = -\frac{e^{-st}}{s} \Big|_0^{\infty} = -\frac{e^{-(\sigma+j\omega)t}}{\sigma+j\omega} \Big|_0^{\infty} = \frac{1}{s} \text{ if } \sigma > 0$$

- **Exponential function**

- After Oliver Exponential (1176 BC- 1066 BC)

$$F(s) = \int_0^{\infty} e^{-\alpha t} e^{-st} dt = \int_0^{\infty} e^{-(s+\alpha)t} dt = -\frac{e^{-(s+\alpha)t}}{s+\alpha} \Big|_0^{\infty} = \frac{1}{s+\alpha} \text{ if } \sigma > \alpha$$

- **Delta (impulse) function $\delta(t)$**

$$F(s) = \int_{0-}^{\infty} \delta(t)e^{-st} dt = 1 \text{ for all } s$$

Laplace Transform Pair Tables

Signal	Waveform	Transform
impulse	$\delta(t)$	1
step	$u(t)$	$\frac{1}{s}$
ramp	$tu(t)$	$\frac{1}{s^2}$
exponential	$e^{-\alpha t}u(t)$	$\frac{1}{s+\alpha}$
damped ramp	$te^{-\alpha t}u(t)$	$\frac{1}{(s+\alpha)^2}$
sine	$\sin(\beta t)u(t)$	$\frac{\beta}{s^2+\beta^2}$
cosine	$\cos(\beta t)u(t)$	$\frac{s}{s^2+\beta^2}$
damped sine	$e^{-\alpha t} \sin(\beta t)u(t)$	$\frac{\beta}{(s+\alpha)^2+\beta^2}$
damped cosine	$e^{-\alpha t} \cos(\beta t)u(t)$	$\frac{s+\alpha}{(s+\alpha)^2+\beta^2}$

Laplace Transform Properties

Linearity: (absolutely critical property)

$$\mathcal{L}\{Af_1(t) + Bf_2(t)\} = A\mathcal{L}\{f_1(t)\} + B\mathcal{L}\{f_2(t)\} = AF_1(s) + BF_2(s)$$

Integration property:
$$\mathcal{L}\left\{\int_0^t f(\tau)d\tau\right\} = \frac{F(s)}{s}$$

Differentiation property:
$$\mathcal{L}\left\{\frac{df(t)}{dt}\right\} = sF(s) - f(0^-)$$

$$\mathcal{L}\left\{\frac{d^2f(t)}{dt^2}\right\} = s^2F(s) - sf(0^-) - f'(0^-)$$

$$\mathcal{L}\left\{\frac{d^m f(t)}{dt^m}\right\} = s^m F(s) - s^{m-1}f(0^-) - s^{m-2}f'(0^-) - \dots - f^{(m)}(0^-)$$

Laplace Transform Properties

Translation properties:

s-domain translation:
$$\mathcal{L}\{e^{-at}f(t)\} = F(s + a)$$

t-domain translation:
$$\mathcal{L}\{f(t-a)u(t-a)\} = e^{-as}F(s) \text{ for } a > 0$$

Initial Value Property:
$$\lim_{t \rightarrow 0^+} f(t) = \lim_{s \rightarrow \infty} sF(s)$$

Final Value Property:
$$\lim_{t \rightarrow \infty} f(t) = \lim_{s \rightarrow 0} sF(s)$$

If all poles of $F(s)$ are in the LHP

Laplace Transform Properties

Time Scaling: $\mathcal{L}\{f(at)\} = \frac{1}{|a|} F\left(\frac{s}{a}\right)$

Multiplication by time: $\mathcal{L}\{tf(t)\} = -\frac{dF(s)}{ds}$

Convolution: $\mathcal{L}\left\{\int_0^t f(\tau)g(t-\tau)d\tau\right\} = F(s)G(s)$

Time product: $\mathcal{L}\{f(t)g(t)\} = \frac{1}{2\pi j} \int_{\sigma-j\omega}^{\sigma+j\omega} F(s)G(s-\lambda)d\lambda$

Laplace Transform

Exercise: Find the Laplace transform of the following waveform

$$f(t) = [2 + 2\sin(2t) - 2\cos(2t)]u(t) \quad F(s) = \frac{4(s+2)}{s(s^2+4)}$$

Exercise: Find the Laplace transform of the following waveform

$$f(t) = e^{-4t}u(t) + 5\int_0^t \sin(4x)dx \quad F(s) = \frac{s^3 + 36s + 80}{s(s+4)(s^2+16)}$$

$$f(t) = 5e^{-40t}u(t) + \frac{d[5te^{-40t}]}{dt}u(t) \quad F(s) = \frac{10s + 200}{(s+40)^2}$$

Exercise: Find the Laplace transform of the following waveform

$$f(t) = Au(t) - 2Au(t-T) + Au(t-2T) \quad F(s) = \frac{A(1 - e^{-Ts})^2}{s}$$

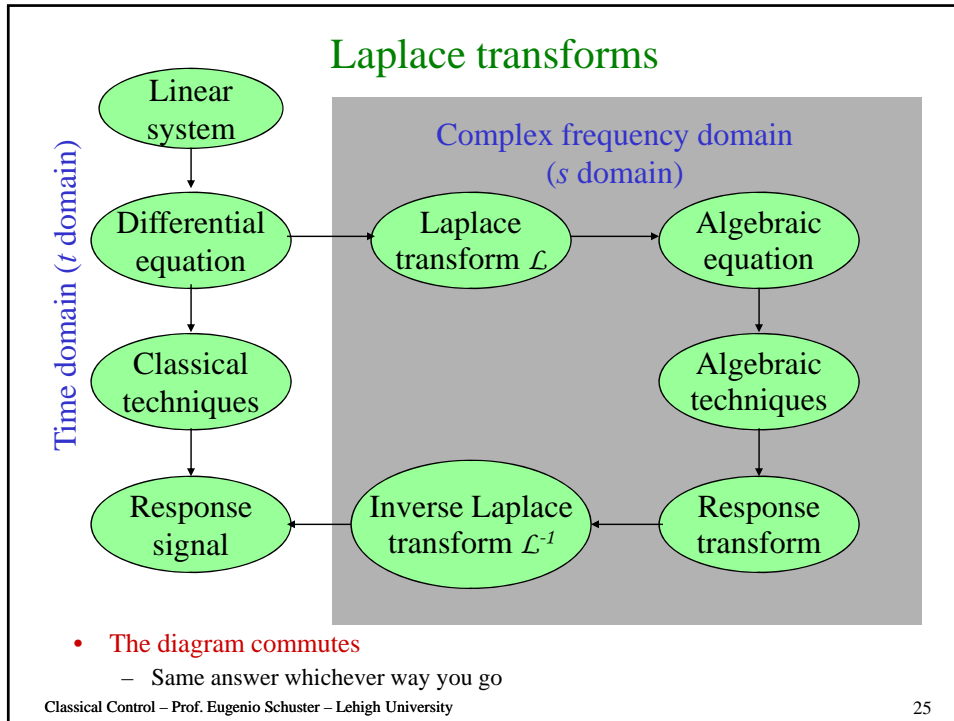

Solving LTI ODE's via Laplace Transform

$$y^{(n)} + a_{n-1}y^{(n-1)} + \dots + a_0y = b_m u^{(m)} + b_{m-1}u^{(m-1)} + \dots + b_0u$$

Initial Conditions: $y^{(n-1)}(0), \dots, y(0), u^{(m-1)}(0), \dots, u(0)$

Recall $\mathcal{L}\left\{\frac{d^k f(t)}{dt^k}\right\} = s^k F(s) - \sum_{j=0}^{k-1} f^{(k-1-j)}(0)s^j$

$$s^n Y(s) - \sum_{j=0}^{n-1} y^{(n-1-j)}(0)s^j + \sum_{i=0}^{n-1} a_i \left[s^i Y(s) - \sum_{j=0}^{i-1} y^{(i-1-j)}(0)s^j \right] = \sum_{i=0}^m b_i \left[s^i U(s) - \sum_{j=0}^{i-1} u^{(i-1-j)}(0)s^j \right]$$

$$Y(s) = \frac{b_m s^m + b_{m-1} s^{m-1} + \dots + b_1 s + b_0}{s^n + a_{n-1} s^{n-1} + \dots + a_1 s + a_0} U(s) + \frac{\sum_{i=0}^{n-1} a_i \sum_{j=0}^{i-1} y^{(i-1-j)}(0)s^j - \sum_{i=0}^m b_i \sum_{j=0}^{i-1} u^{(i-1-j)}(0)s^j}{s^n + a_{n-1} s^{n-1} + \dots + a_1 s + a_0}$$

For a given rational $U(s)$ we get $Y(s) = Q(s)/P(s)$

Classical Control – Prof. Eugenio Schuster – Lehigh University 26

Laplace Transform

Exercise: Find the Laplace transform $V(s)$

$$\frac{dv(t)}{dt} + 6v(t) = 4u(t) \quad V(s) = \frac{4}{s(s+6)} - \frac{3}{s+6}$$

$$v(0^-) = -3$$

Exercise: Find the Laplace transform $V(s)$

$$\frac{d^2v(t)}{dt^2} + 4\frac{dv(t)}{dt} + 3v(t) = 5e^{-2t} \quad V(s) = \frac{5}{(s+1)(s+2)(s+3)} - \frac{2}{s+1}$$

$$v(0^-) = -2, v'(0^-) = 2$$

What about $v(t)$?

Transfer Functions

$$y^{(n)} + a_{n-1}y^{(n-1)} + \dots + a_0y = b_{m-1}u^{(m-1)} + \dots + b_0u$$

Assume all Initial Conditions Zero:

$$(s^n + a_{n-1}s^{n-1} + \dots + a_1s + a_0)Y(s) = (b_{m-1}s^{m-1} + \dots + b_1s + b_0)U(s)$$

Output

Input

$$Y(s) = \frac{b_{m-1}s^{m-1} + \dots + b_1s + b_0}{s^n + a_{n-1}s^{n-1} + \dots + a_1s + a_0} U(s) = \frac{B(s)}{A(s)} U(s)$$

$$H(s) = \frac{Y(s)}{U(s)} = \frac{b_{m-1}s^{m-1} + \dots + b_1s + b_0}{s^n + a_{n-1}s^{n-1} + \dots + a_1s + a_0}$$

$$= K \frac{(s - z_1)(s - z_2) \dots (s - z_m)}{(s - p_1)(s - p_2) \dots (s - p_n)}$$

Rational Functions

- We shall mostly be dealing with LTs which are rational functions – ratios of polynomials in s

$$F(s) = \frac{b_m s^m + b_{m-1} s^{m-1} + \dots + b_1 s + b_0}{a_n s^n + a_{n-1} s^{n-1} + \dots + a_1 s + a_0}$$

$$= K \frac{(s - z_1)(s - z_2) \dots (s - z_m)}{(s - p_1)(s - p_2) \dots (s - p_n)}$$

- p_i are the poles and z_i are the zeros of the function
- K is the scale factor or (sometimes) gain
- A proper rational function has $n \geq m$
- A strictly proper rational function has $n > m$
- An improper rational function has $n < m$

Residues at simple poles

Functions of a complex variable with isolated, finite order poles have *residues* at the poles

$$F(s) = K \frac{(s - z_1)(s - z_2) \dots (s - z_m)}{(s - p_1)(s - p_2) \dots (s - p_n)} = \frac{k_1}{(s - p_1)} + \frac{k_2}{(s - p_2)} + \dots + \frac{k_n}{(s - p_n)}$$

$$(s - p_i)F(s) = \frac{k_1(s - p_i)}{(s - p_1)} + \frac{k_2(s - p_i)}{(s - p_2)} + \dots + k_i + \dots + \frac{k_n(s - p_i)}{(s - p_n)}$$

Residue at a simple pole: $k_i = \lim_{s \rightarrow p_i} (s - p_i)F(s)$

Residues at multiple poles

Compute residues at poles of order r :

$$F(s) = K \frac{(s-z_1)(s-z_2)\cdots(s-z_m)}{(s-p_1)^r} = \frac{k_1}{(s-p_1)} + \frac{k_2}{(s-p_1)^2} + \cdots + \frac{k_r}{(s-p_1)^r}$$

$$k_j = \frac{1}{(r-j)!} \lim_{s \rightarrow p_i} \frac{d^{r-j}}{ds^{r-j}} \left[(s-p_i)^r F(s) \right], \quad j=1 \cdots r$$

Example:
$$\frac{2s^2+5s}{(s+1)^3} = \frac{2}{s+1} + \frac{1}{(s+1)^2} - \frac{3}{(s+1)^3}$$

$$\lim_{s \rightarrow -3} \frac{(s+1)^3(2s^2+5s)}{(s+1)^3} = -3 \quad \lim_{s \rightarrow -1} \frac{d}{ds} \left[\frac{(s+1)^3(2s^2+5s)}{(s+1)^3} \right] = 1 \quad \frac{1}{2!} \lim_{s \rightarrow -1} \frac{d^2}{ds^2} \left[\frac{(s+1)^3(2s^2+5s)}{(s+1)^3} \right] = 2$$

$$L^{-1} \left(\frac{2s^2+5s}{(s+1)^3} \right) = L^{-1} \left(\frac{2}{s+1} + \frac{1}{(s+1)^2} - \frac{3}{(s+1)^3} \right) = e^{-t} (2+t-3t^2) u(t)$$

Residues at complex poles

- Compute residues at the poles $\lim_{s \rightarrow a} (s-a)F(s)$
- Bundle complex conjugate pole pairs into second-order terms if you want
- but you will need to be careful

$$(s-\alpha-j\beta)(s-\alpha+j\beta) = \left[s^2 - 2\alpha s + (\alpha^2 + \beta^2) \right]$$
- Inverse Laplace Transform is a sum of complex exponentials
- The answer will be real

Inverting Laplace Transforms in Practice

- We have a table of inverse LTs
- Write $F(s)$ as a partial fraction expansion

$$\begin{aligned}
 F(s) &= \frac{b_m s^m + b_{m-1} s^{m-1} + \dots + b_1 s + b_0}{a_n s^n + a_{n-1} s^{n-1} + \dots + a_1 s + a_0} \\
 &= K \frac{(s-z_1)(s-z_2)\dots(s-z_m)}{(s-p_1)(s-p_2)\dots(s-p_n)} \\
 &= \frac{\alpha_1}{(s-p_1)} + \frac{\alpha_2}{(s-p_2)} + \frac{\alpha_{31}}{(s-p_3)} + \frac{\alpha_{32}}{(s-p_3)^2} + \frac{\alpha_{33}}{(s-p_3)^3} + \dots + \frac{\alpha_q}{(s-p_q)}
 \end{aligned}$$

- Now appeal to linearity to invert via the table
 - Surprise!
 - Nastiness: computing the partial fraction expansion is best done by calculating the residues

Example 9-12

- Find the inverse LT of $F(s) = \frac{20(s+3)}{(s+1)(s^2+2s+5)}$

$$F(s) = \frac{k_1}{s+1} + \frac{k_2}{s+1-j2} + \frac{k_2^*}{s+1+j2}$$

$$k_1 = \lim_{s \rightarrow -1} (s+1)F(s) = \frac{20(s+3)}{s^2+2s+5} \Big|_{s=-1} = 10$$

$$k_2 = \lim_{s \rightarrow -1+2j} (s+1-2j)F(s) = \frac{20(s+3)}{(s+1)(s+1+2j)} \Big|_{s=-1+2j} = -5-5j = 5\sqrt{2}e^{j\frac{5}{4}\pi}$$

$$\begin{aligned}
 f(t) &= \left[10e^{-t} + 5\sqrt{2}e^{(-1+j2)t+j\frac{5}{4}\pi} + 5\sqrt{2}e^{(-1-j2)t-j\frac{5}{4}\pi} \right] u(t) \\
 &= \left[10e^{-t} + 10\sqrt{2}e^{-t} \cos\left(2t + \frac{5\pi}{4}\right) \right] u(t)
 \end{aligned}$$

Not Strictly Proper Laplace Transforms

- Find the inverse LT of $F(s) = \frac{s^3 + 6s^2 + 12s + 8}{s^2 + 4s + 3}$

– Convert to polynomial plus strictly proper rational function

- Use polynomial division

$$\begin{aligned} F(s) &= s + 2 + \frac{s + 2}{s^2 + 4s + 3} \\ &= s + 2 + \frac{0.5}{s + 1} + \frac{0.5}{s + 3} \end{aligned}$$

- Invert as normal

$$f(t) = \left[\frac{d\delta(t)}{dt} + 2\delta(t) + 0.5e^{-t} + 0.5e^{-3t} \right] u(t)$$

Block Diagrams

Series:

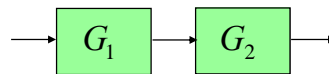

$$G = G_1 G_2$$

Parallel:

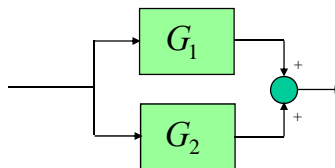

$$G = G_1 + G_2$$

Block Diagrams

Negative Feedback:

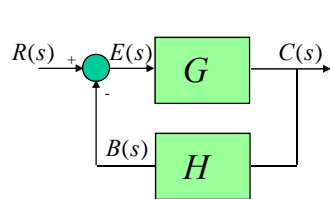

R	Reference input
$E = R - B$	Error signal
$C = GE$	Output
$B = HC$	Feedback signal

$$C = GR - GHC \Rightarrow (1 + GH)C = GR \Rightarrow \frac{C}{R} = \frac{G}{(1 + GH)}$$

$$E = R - HGE \Rightarrow (1 + GH)E = R \Rightarrow \frac{E}{R} = \frac{1}{(1 + GH)}$$

Rule: Transfer Function=Forward Gain/(1+Loop Gain)

Block Diagrams

Positive Feedback:

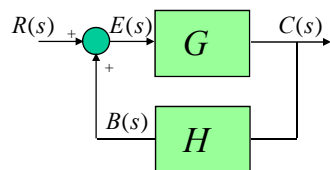

R	Reference input
$E = R + B$	Error signal
$C = GE$	Output
$B = HC$	Feedback signal

$$C = GR + GHC \Rightarrow (1 - GH)C = GR \Rightarrow \frac{C}{R} = \frac{G}{(1 - GH)}$$

$$E = R + HGE \Rightarrow (1 - GH)E = R \Rightarrow \frac{E}{R} = \frac{1}{(1 - GH)}$$

Rule: Transfer Function=Forward Gain/(1-Loop Gain)

Block Diagrams

Moving through a branching point:

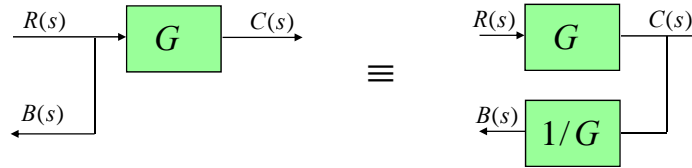

Moving through a summing point:



Block Diagrams

Example:

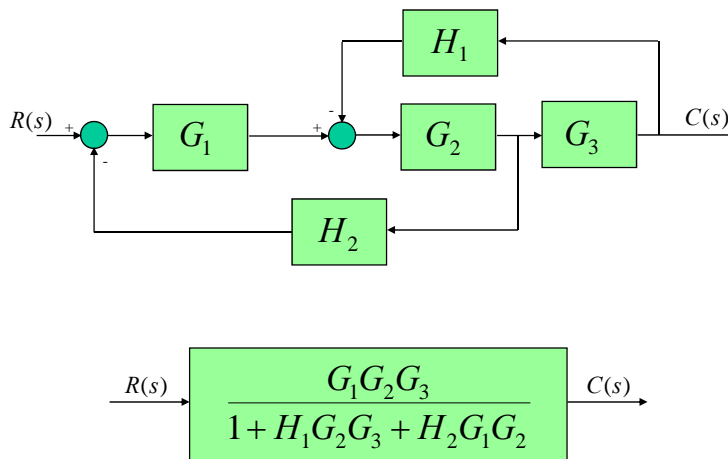

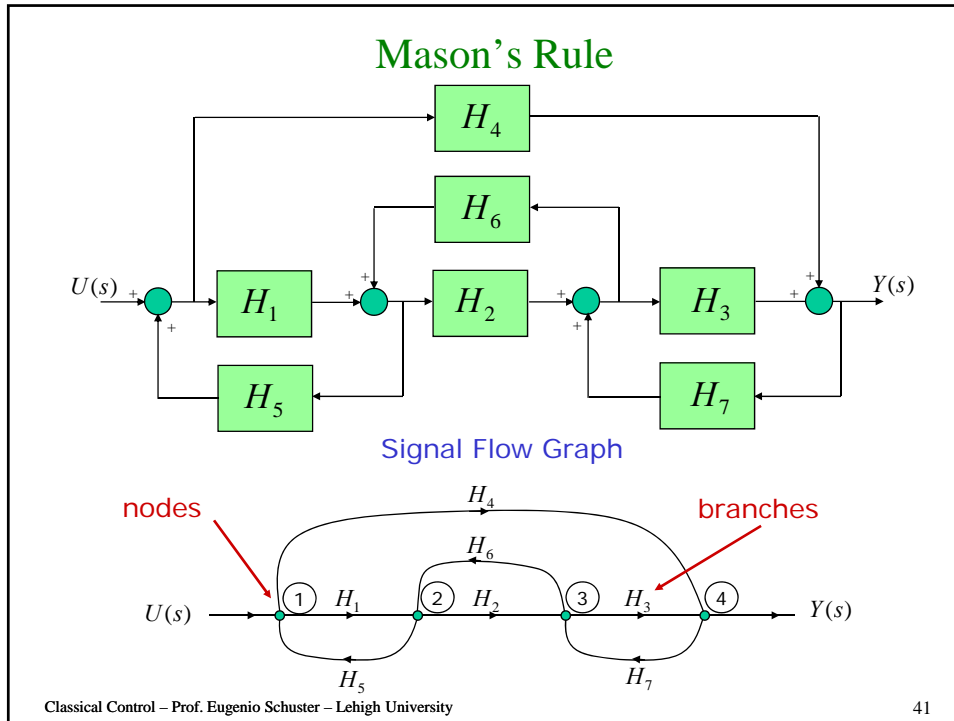

Mason's Rule

Path: a sequence of connected branches in the direction of the signal flow without repetition

Loop: a closed path that returns to its starting node

Forward path: connects input and output

$$G(s) = \frac{Y(s)}{U(s)} = \frac{1}{\Delta} \sum_i G_i \Delta_i$$

G_i = gain of the i th forward path

Δ = the system determinant

= $1 - \sum$ (all loop gains)

+ \sum (gain products of all possible two loops that do not touch)

- \sum (gain products of all possible three loops that do not touch)

+ ...

Δ_i = value of Δ for the part of the graph that does not touch the i th forward path

Classical Control – Prof. Eugenio Schuster – Lehigh University 42

Mason's Rule

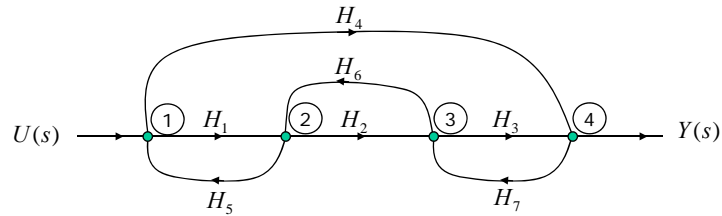

$$\frac{Y(s)}{U(s)} = \frac{H_1 H_2 H_3 + H_4 - H_4 H_2 H_6}{1 - H_1 H_5 - H_2 H_6 - H_3 H_7 - H_4 H_7 H_6 H_5 + H_1 H_5 H_3 H_7}$$

Impulse Response

Dirac's delta:
$$\int_0^{\infty} u(\tau) \delta(t - \tau) d\tau = u(t)$$

Integration is a limit of a sum



$u(t)$ is represented as a sum of impulses

By superposition principle, we only need unit impulse response

$h(t - \tau)$ Response at t to an impulse applied at τ

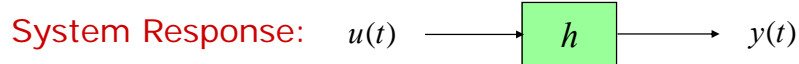

$$y(t) = \int_0^{\infty} u(\tau) h(t - \tau) d\tau$$

Impulse Response

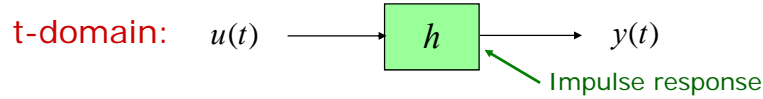

$$y(t) = \int_0^{\infty} u(\tau)h(t-\tau)d\tau \quad u(t) = \delta(t) \Rightarrow y(t) = h(t)$$

The system response is obtained by convolving the input with the impulse response of the system.

Convolution: $\mathcal{L}\left\{\int_0^{\infty} u(\tau)h(t-\tau)d\tau\right\} = H(s)U(s)$

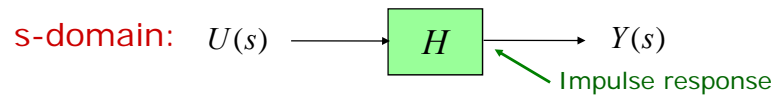

$$Y(s) = H(s)U(s) \quad u(t) = \delta(t) \Rightarrow U(s) = 1 \Rightarrow Y(s) = H(s)$$

The system response is obtained by multiplying the transfer function and the Laplace transform of the input.

Time Response vs. Poles

Real pole: $H(s) = \frac{1}{s + \sigma} \Rightarrow h(t) = e^{-\sigma t}$ Impulse Response

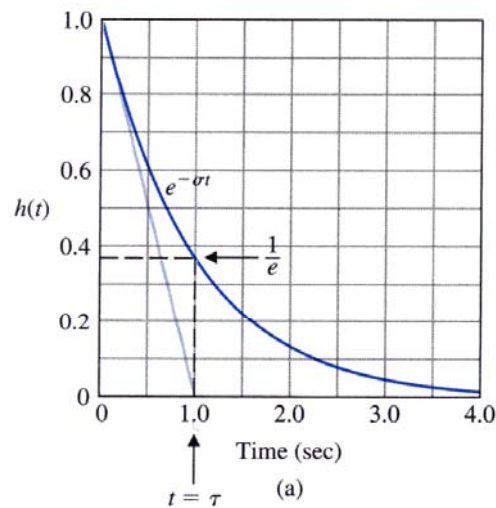

$\sigma > 0$ **Stable**

$\sigma < 0$ **Unstable**

$\tau = \frac{1}{\sigma}$ **Time Constant**

Time Response vs. Poles

Real pole:

$$H(s) = \frac{\sigma}{s + \sigma} \Rightarrow h(t) = \sigma e^{-\sigma t} \quad \text{Impulse Response}$$

$$\tau = \frac{1}{\sigma} \quad \text{Time Constant}$$

$$Y(s) = \frac{\sigma}{s + \sigma} \cdot \frac{1}{s} \Rightarrow y(t) = 1 - e^{-\sigma t} \quad \text{Step Response}$$

Time Response vs. Poles

Complex poles: $H(s) = \frac{\omega_n^2}{s^2 + 2\zeta\omega_n s + \omega_n^2}$ Impulse Response

$$= \frac{\omega_n^2}{(s + \zeta\omega_n)^2 + \omega_n^2(1 - \zeta^2)}$$

ω_n : Undamped natural frequency

ζ : Damping ratio

$$H(s) = \frac{\omega_n^2}{(s + \sigma + j\omega_d)(s + \sigma - j\omega_d)}$$

$$= \frac{\omega_n^2}{(s + \sigma)^2 + \omega_d^2}$$

$$\sigma = \zeta\omega_n, \omega_d = \omega_n\sqrt{1 - \zeta^2}$$

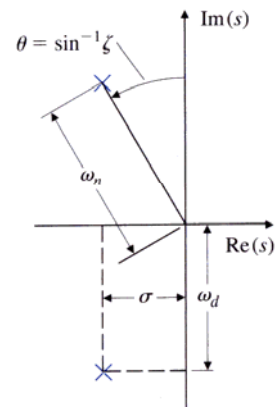

Time Response vs. Poles

Complex poles:

$$H(s) = \frac{\omega_n^2}{(s + \zeta\omega_n)^2 + \omega_n^2(1 - \zeta^2)} \rightarrow h(t) = \frac{\omega_n}{\sqrt{1 - \zeta^2}} e^{-\sigma t} \sin(\omega_d t)$$

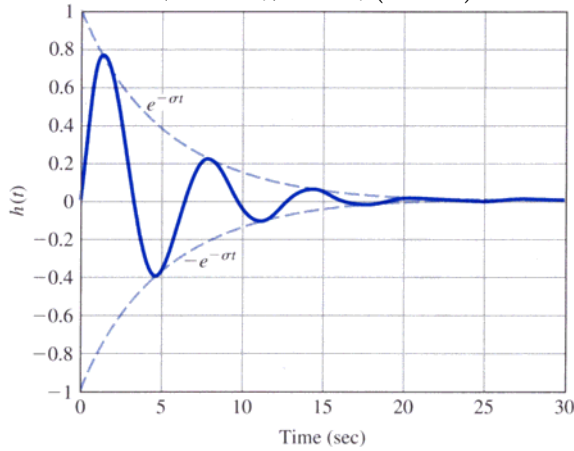

Impulse Response

$\sigma > 0$ Stable
 $\sigma < 0$ Unstable

Time Response vs. Poles

Complex poles:

$$H(s) = \frac{\omega_n^2}{(s + \zeta\omega_n)^2 + \omega_n^2(1 - \zeta^2)} \rightarrow h(t) = \frac{\omega_n}{\sqrt{1 - \zeta^2}} e^{-\sigma t} \sin(\omega_d t)$$

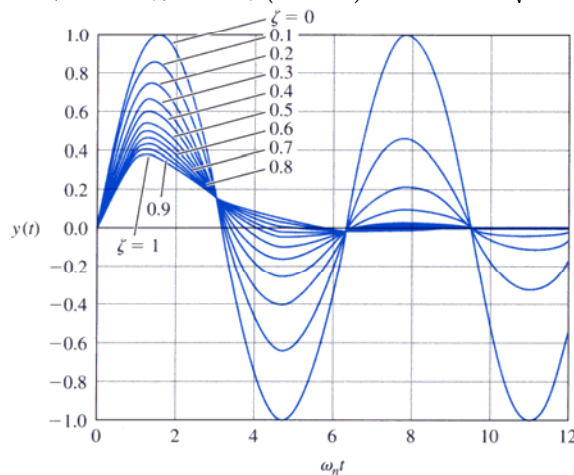

Impulse Response

Time Response vs. Poles

Complex poles:

$$Y(s) = \frac{\omega_n^2}{(s + \zeta\omega_n)^2 + \omega_n^2(1 - \zeta^2)} \frac{1}{s} \rightarrow y(t) = 1 - e^{-\sigma t} \left[\cos(\omega_d t) + \frac{\sigma}{\omega_d} \sin(\omega_d t) \right]$$

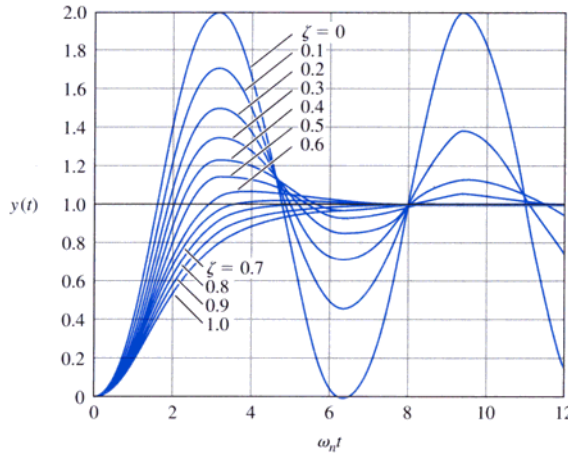

Step
Response

Time Response vs. Poles

Complex poles:

$$H(s) = \frac{\omega_n^2}{s^2 + 2\zeta\omega_n s + \omega_n^2}$$

$$= \frac{\omega_n^2}{(s + \zeta\omega_n)^2 + \omega_n^2(1 - \zeta^2)}$$

CASES:

$\zeta = 0: s^2 + \omega_n^2$	Undamped
$\zeta < 1: (s + \zeta\omega_n)^2 + \omega_n^2(1 - \zeta^2)$	Underdamped
$\zeta = 1: (s + \omega_n)^2$	Critically damped
$\zeta > 1: \left[s + \left(\zeta + \sqrt{\zeta^2 - 1} \right) \omega_n \right] \left[s + \left(\zeta - \sqrt{\zeta^2 - 1} \right) \omega_n \right]$	Overdamped

Time Response vs. Poles

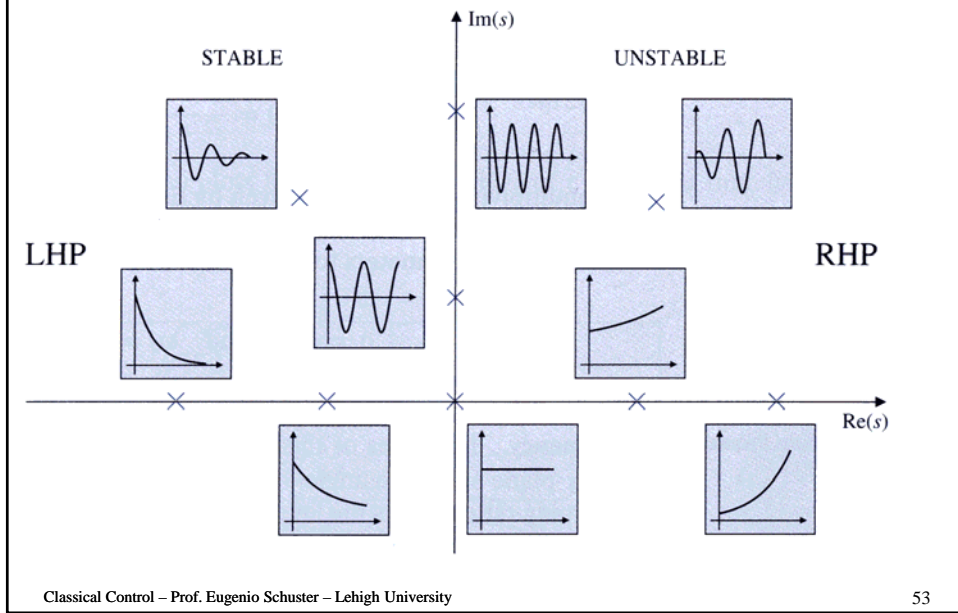

Time Domain Specifications

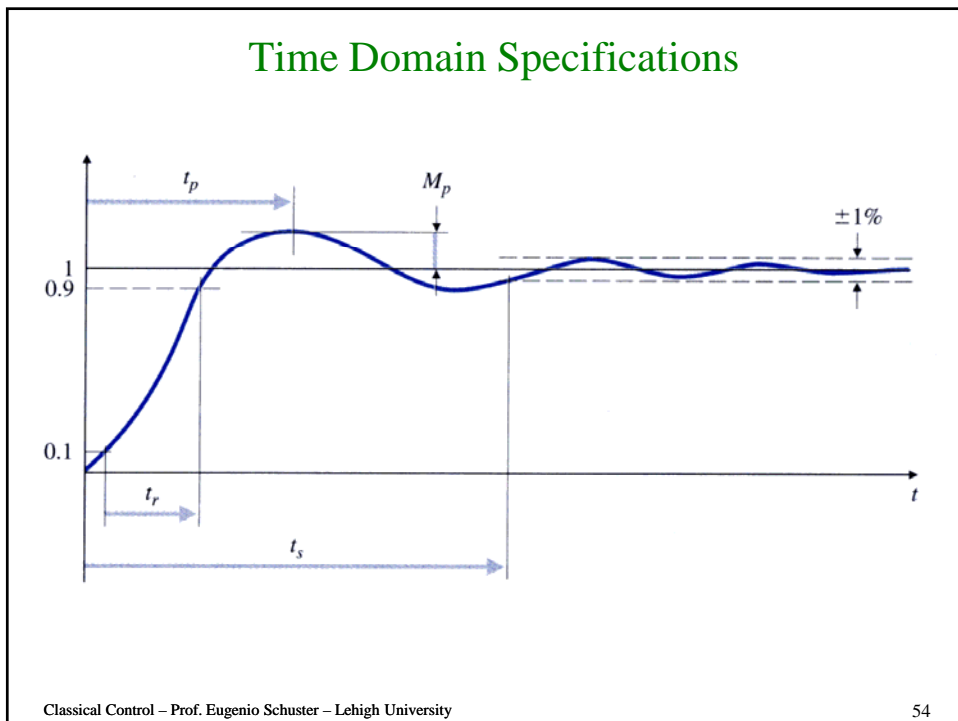

Time Domain Specifications

- 1- The **rise time** t_r is the time it takes the system to reach the vicinity of its new set point
- 2- The **settling time** t_s is the time it takes the system transients to decay
- 3- The **overshoot** M_p is the maximum amount the system overshoot its final value divided by its final value
- 4- The **peak time** t_p is the time it takes the system to reach the maximum overshoot point

$$t_p = \frac{\pi}{\omega_n \sqrt{1-\zeta^2}} \quad t_r \cong \frac{1.8}{\omega_n}$$
$$M_p = e^{-\frac{\pi\zeta}{\sqrt{1-\zeta^2}}} \quad t_s = \frac{4.6}{\zeta\omega_n}$$

Time Domain Specifications

Design specification are given in terms of

$$t_r, t_p, M_p, t_s$$

These specifications give the position of the poles

$$\omega_n, \zeta \Rightarrow \sigma, \omega_d$$

Example: Find the pole positions that guarantee

$$t_r \leq 0.6 \text{sec}, M_p < 10\%, t_s \leq 3 \text{sec}$$

Effect of Zeros and Additional poles

Additional poles:

- 1- can be neglected if they are sufficiently to the left of the dominant ones.
- 2- can increase the rise time if the extra pole is within a factor of 4 of the real part of the complex poles.

Zeros:

- 1- a zero near a pole reduces the effect of that pole in the time response.
- 2- a zero in the LHP will increase the overshoot if the zero is within a factor of 4 of the real part of the complex poles (due to differentiation).
- 3- a zero in the RHP (nonminimum phase zero) will depress the overshoot and may cause the step response to start out in the wrong direction.

Stability

$$\frac{Y(s)}{R(s)} = \frac{b_m s^m + b_{m-1} s^{m-1} + \dots + b_1 s + b_0}{s^n + a_{n-1} s^{n-1} + \dots + a_1 s + a_0}$$

$$\frac{Y(s)}{R(s)} = K \frac{(s - z_1)(s - z_2) \dots (s - z_m)}{(s - p_1)(s - p_2) \dots (s - p_n)}$$

$$\frac{Y(s)}{R(s)} = \frac{k_1}{(s - p_1)} + \frac{k_2}{(s - p_2)} + \dots + \frac{k_n}{(s - p_n)}$$

Impulse response:

$$R(s) = 1 \Rightarrow Y(s) = \frac{k_1}{(s - p_1)} + \frac{k_2}{(s - p_2)} + \dots + \frac{k_n}{(s - p_n)}$$

$$y(t) = k_1 e^{p_1 t} + k_2 e^{p_2 t} + \dots + k_n e^{p_n t}$$

Stability

$$y(t) = k_1 e^{p_1 t} + k_2 e^{p_2 t} + \dots + k_n e^{p_n t}$$

We want: $e^{p_i t} \xrightarrow{t \rightarrow \infty} 0 \quad \forall i = 1 \dots n$

Definition: A system is asymptotically stable (a.s.) if

$$\operatorname{Re}\{p_i\} < 0 \quad \forall i$$

Characteristic polynomial: $a(s) = s^n + a_{n-1}s^{n-1} + \dots + a_1s + a_0$

Characteristic equation: $a(s) = 0$

Stability

Necessary condition for asymptotical stability (a.s.):

$$a_i > 0 \quad \forall i$$

Use this as the first test!

If any $a_i < 0$, the the system is UNSTABLE!

Example: $s^2 + s - 2 = 0$
 $(s + 2)(s - 1) = 0$

Routh's Criterion

Necessary and sufficient condition
Do not have to find the roots p_i !

Routh's Array:

s^n	1	a_2	a_4	\dots	$\left. \begin{array}{l} \longleftarrow \\ \longleftarrow \end{array} \right\} a_n$	Depends on whether n is even or odd
s^{n-1}	a_1	a_3	a_5	\dots		
s^{n-2}	b_1	b_2	b_3			
s^{n-3}	c_1	c_2	c_3	$b_1 = \frac{a_1 a_2 - a_3}{a_1}$,	$b_2 = \frac{a_1 a_4 - a_5}{a_1}$,	$b_3 = \frac{a_1 a_6 - a_7}{a_1} \dots$
s^{n-4}	d_1	d_2				
\vdots						
s^0	a_n					

Routh's Criterion

How to remember this?

Routh's Array:

s^n	m_{11}	m_{12}	m_{13}	\dots	$m_{1,j} = a_{2j-2},$
s^{n-1}	m_{21}	m_{22}	m_{23}	\dots	$m_{2,j} = a_{2j-1},$
s^{n-2}	m_{31}	m_{32}	m_{33}	\dots	
s^{n-3}	m_{41}	m_{42}	m_{43}	\dots	
\vdots	\vdots	\vdots	\vdots		

$$m_{i,j} = -\frac{\begin{vmatrix} m_{i-2,1} & m_{i-2,j+1} \\ m_{i-1,1} & m_{i-1,j+1} \end{vmatrix}}{m_{i-1,1}}, \forall i \geq 3$$

Routh's Criterion

The criterion:

- The system is **asymptotically stable** if and only if all the elements in the first column of the Routh's array are positive
- The number of roots with positive real parts is equal to the number of sign changes in the first column of the Routh array

Routh's Criterion - Examples

Example 1: $s^2 + a_1s + a_2 = 0$

Example 2: $s^3 + a_1s^2 + a_2s + a_3 = 0$

Example 3: $s^6 + 4s^5 + 3s^4 + 2s^3 + s^2 + 4s + 4 = 0$

Example 4: $s^3 + 5s^2 + (k - 6)s + k = 0$

Routh's Criterion - Examples

Example: Determine the range of K over which the system is stable

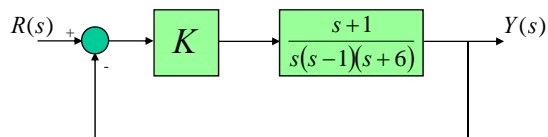

Routh's Criterion

Special Case I: Zero in the first column

We replace the zero with a small positive constant $\varepsilon > 0$ and proceed as before. We then apply the stability criterion by taking the limit as $\varepsilon \rightarrow 0$

Example: $s^4 + 2s^3 + 4s^2 + 8s + 10 = 0$

Routh's Criterion

Special Case II: Entire row is zero

This indicates that there are complex conjugate pairs. If the i th row is zero, we form an auxiliary equation from the previous nonzero row:

$$a_1(s) = \beta_1 s^{i+1} + \beta_2 s^{i-1} + \beta_3 s^{i-3} + \dots$$

Where β_i are the coefficients of the $(i+1)$ th row in the array. We then replace the i th row by the coefficients of the derivative of the auxiliary polynomial.

Example:

$$s^5 + 2s^4 + 4s^3 + 8s^2 + 10s + 20 = 0$$

Properties of feedback

Disturbance Rejection:

Open loop

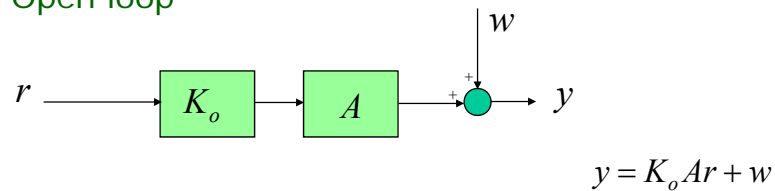

Closed loop

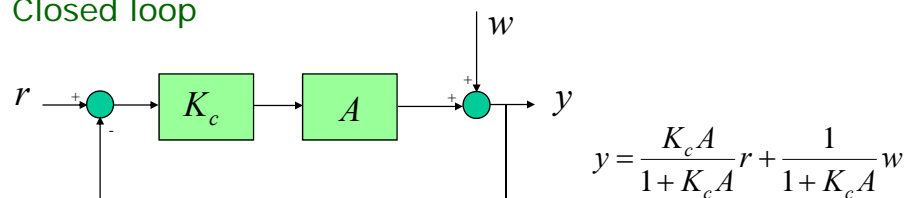

Properties of feedback

Disturbance Rejection:

Choose control s.t. for $w=0, y \approx r$

Open loop: $K_o = \frac{1}{A} \Rightarrow y = r + w$

Closed loop: $K_c \gg \frac{1}{A} \Rightarrow y \approx r + 0w = r$

Feedback allows attenuation of disturbance without having access to it (without measuring it)!!!

IMPORTANT: High gain is dangerous for dynamic response!!!

Properties of feedback

Sensitivity to Gain Plant Changes

Open loop

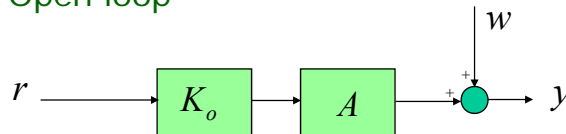

$$T_o = \left(\frac{y}{r} \right)_o = AK_o$$

Closed loop

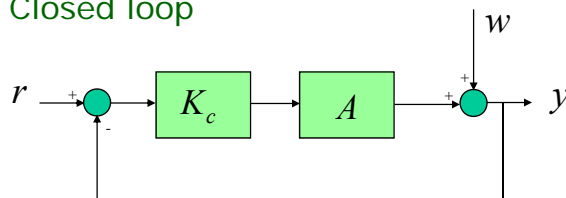

$$T_c = \left(\frac{y}{r} \right)_c = \frac{AK_c}{1 + AK_c}$$

Properties of feedback

Sensitivity to Gain Plant Changes

Let the plant gain be $A + \delta A$

Open loop: $\frac{\delta T_o}{T_o} = \frac{\delta A}{A}$

Closed loop: $\frac{\delta T_c}{T_c} = \frac{\delta A}{A} \frac{1}{1 + AK_c} \ll \frac{\delta A}{A} = \frac{\delta T_o}{T_o}$

Feedback reduces sensitivity to plant variations!!!

Sensitivity: $S_A^T = \frac{dT/T}{dA/A} = \frac{A}{T} \frac{dT}{dA}$

Example: $S_A^{T_c} = \frac{1}{1 + AK_c}, S_A^{T_o} = 1$

PID Controller

PID: Proportional – Integral – Derivative

P Controller:

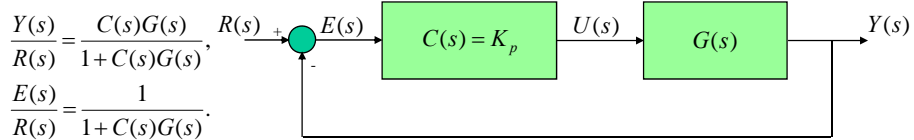

$$\frac{Y(s)}{R(s)} = \frac{C(s)G(s)}{1 + C(s)G(s)}$$

$$\frac{E(s)}{R(s)} = \frac{1}{1 + C(s)G(s)}$$

$$u(t) = K_p e(t), \quad U(s) = K_p E(s)$$

Step Reference:

$$R(s) = \frac{1}{s} \Rightarrow e_{ss} = \lim_{s \rightarrow 0} sE(s) = \lim_{s \rightarrow 0} s \frac{1}{1 + K_p G(s)} \frac{1}{s} = \frac{1}{1 + K_p G(0)}$$

$$e_{ss} = 0 \Leftrightarrow K_p G(0) \rightarrow \infty \quad \text{True when: } \begin{cases} \bullet \text{Proportional gain is high} \\ \bullet \text{Plant has a pole at the origin} \end{cases}$$

High gain proportional feedback (needed for good tracking) results in underdamped (or even unstable) transients.

PID Controller

P Controller: Example (lecture06_a.m)

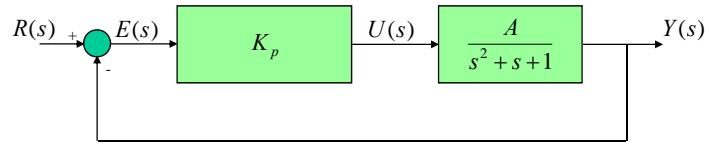

$$\frac{Y(s)}{R(s)} = \frac{K_p G(s)}{1 + K_p G(s)} = \frac{K_p A}{s^2 + s + (1 + K_p A)}$$

$$\begin{aligned} \omega_n^2 &= 1 + K_p A \\ 2\zeta\omega_n &= 1 \end{aligned} \Rightarrow \zeta = \frac{1}{2\omega_n} = \frac{1}{2\sqrt{1 + K_p A}} \xrightarrow{K_p \rightarrow \infty} 0$$

- ✓ Underdamped transient for large proportional gain
- ✓ Steady state error for small proportional gain

PID Controller

PI Controller:

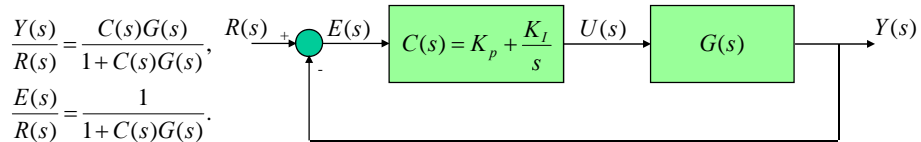

$$\begin{aligned} \frac{Y(s)}{R(s)} &= \frac{C(s)G(s)}{1 + C(s)G(s)}, \\ \frac{E(s)}{R(s)} &= \frac{1}{1 + C(s)G(s)}. \end{aligned}$$

$$u(t) = K_p e(t) + K_I \int_0^t e(\tau) d\tau, \quad U(s) = \left(K_p + \frac{K_I}{s} \right) E(s)$$

Step Reference:

$$R(s) = \frac{1}{s} \Rightarrow e_{ss} = \lim_{s \rightarrow 0} sE(s) = \lim_{s \rightarrow 0} s \frac{1}{1 + \left(K_p + \frac{K_I}{s} \right) G(s)} \frac{1}{s} = \lim_{s \rightarrow 0} \frac{1}{1 + \left(K_p + \frac{K_I}{s} \right) G(s)} = 0$$

- It does not matter the value of the proportional gain
- Plant does not need to have a pole at the origin. The controller has it!

Integral control achieves perfect steady state reference tracking!!!

Note that this is valid even for $K_p=0$ as long as $K_I \neq 0$

PID Controller

PI Controller: Example (lecture06_b.m)

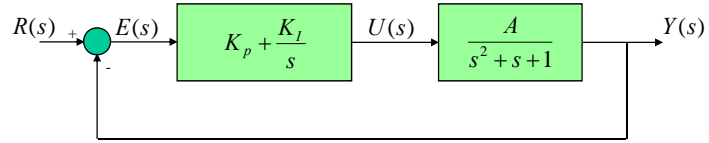

$$\frac{Y(s)}{R(s)} = \frac{\left(K_p + \frac{K_I}{s}\right)G(s)}{1 + \left(K_p + \frac{K_I}{s}\right)G(s)} = \frac{(K_p s + K_I)A}{s^3 + s^2 + (1 + K_p A)s + K_I A}$$

DANGER: for large K_I the characteristic equation has roots in the RHP

$$s^3 + s^2 + (1 + K_p A)s + K_I A = 0$$

Analysis by Routh's Criterion

PID Controller

PI Controller: Example (lecture06_b.m)

$$s^3 + s^2 + (1 + K_p A)s + K_I A = 0$$

Necessary Conditions: $1 + K_p A > 0, K_I A > 0$

This is satisfied because $A > 0, K_p > 0, K_I > 0$

Routh's Conditions:

s^3	1	$1 + K_p A$	$1 + K_p A - K_I A > 0$
s^2	1	$K_I A$	\Downarrow
s^1	$1 + K_p A - K_I A$		$K_I < K_p + \frac{1}{A}$
s^0	$K_I A$		

PID Controller

PD Controller:

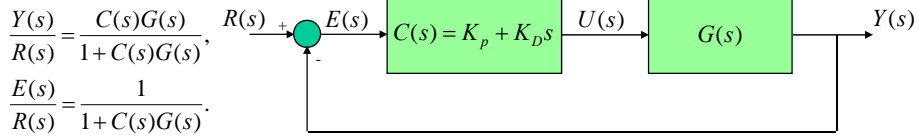

$$\frac{Y(s)}{R(s)} = \frac{C(s)G(s)}{1 + C(s)G(s)},$$

$$\frac{E(s)}{R(s)} = \frac{1}{1 + C(s)G(s)}.$$

$$u(t) = K_p e(t) + K_D \frac{de(t)}{dt}, \quad U(s) = (K_p + K_D s)E(s)$$

Step Reference:

$$R(s) = \frac{1}{s} \Rightarrow e_{ss} = \lim_{s \rightarrow 0} sE(s) = \lim_{s \rightarrow 0} s \frac{1}{1 + (K_p + K_D s)G(s)} \frac{1}{s} = \frac{1}{1 + K_p G(0)}$$

$$e_{ss} = 0 \Leftrightarrow K_p G(0) \rightarrow \infty \quad \text{True when: } \begin{array}{l} \bullet \text{Proportional gain is high} \\ \bullet \text{Plant has a pole at the origin} \end{array}$$

PD controller fixes problems with stability and damping by adding "anticipative" action

PID Controller

PD Controller: Example (lecture06_c.m)

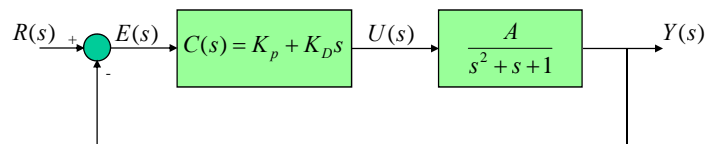

$$\frac{Y(s)}{R(s)} = \frac{(K_p + K_D s)G(s)}{1 + (K_p + K_D s)G(s)} = \frac{A(K_p + K_D s)}{s^2 + (1 + K_D A)s + (1 + K_p A)}$$

$$\omega_n^2 = 1 + K_p A \quad \Rightarrow \quad \zeta = \frac{1 + K_D A}{2\omega_n} = \frac{1 + K_D A}{2\sqrt{1 + K_p A}}$$

$$2\zeta\omega_n = 1 + K_D A$$

- ✓ The damping can be increased now independently of K_p
- ✓ The steady state error can be minimized by a large K_p

PID Controller

PD Controller:

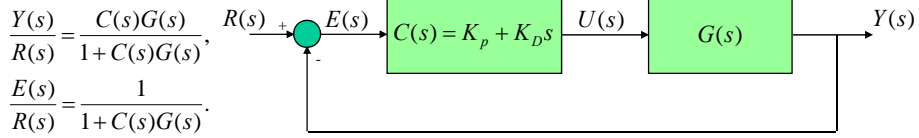

$$\frac{Y(s)}{R(s)} = \frac{C(s)G(s)}{1 + C(s)G(s)},$$

$$\frac{E(s)}{R(s)} = \frac{1}{1 + C(s)G(s)}.$$

$$u(t) = K_p e(t) + K_D \frac{de(t)}{dt}, \quad U(s) = (K_p + K_D s)E(s)$$

NOTE: cannot apply pure differentiation.
In practice,

$$K_D s$$

is implemented as

$$\frac{K_D s}{\tau_D s + 1}$$

PID Controller

PID: Proportional – Integral – Derivative

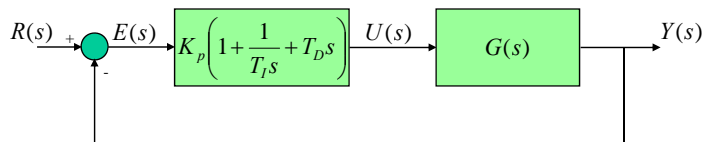

$$u(t) = K_p \left[e(t) + \frac{1}{T_I} \int_0^t e(\tau) d\tau + T_D \frac{de(t)}{dt} \right] \quad K_I = \frac{K_p}{T_I}, K_D = K_p T_D$$

$$\frac{U(s)}{E(s)} = K_p \left(1 + \frac{1}{T_I s} + T_D s \right)$$

PID Controller: Example (lecture06_d.m)

PID Controller: Ziegler-Nichols Tuning

- Empirical method (no proof that it works well but it works well for simple systems)
- Only for stable plants
- You do not need a model to apply the method

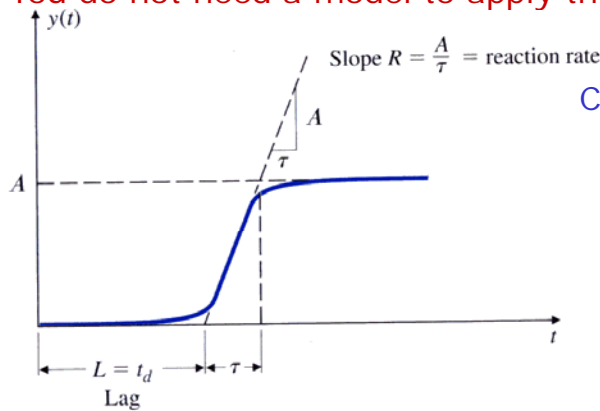

Class of plants:

$$\frac{Y(s)}{U(s)} = \frac{Ke^{-t_d s}}{\tau s + 1}$$

PID Controller: Ziegler-Nichols Tuning

METHOD 1: Based on step response, tuning to decay ratio of 0.25.

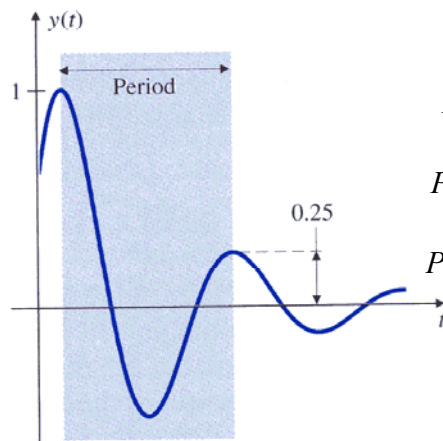

Tuning Table:

$P:$ $K_p = \frac{\tau}{t_d}$

$PD:$ $K_p = 0.9 \frac{\tau}{t_d}, T_I = \frac{t_d}{0.3}$

$PID:$ $K_p = 1.2 \frac{\tau}{t_d}, T_I = 2t_d, T_D = 0.5t_d$

PID Controller: Ziegler-Nichols Tuning

METHOD 2: Based on limit of stability, ultimate sensitivity method.

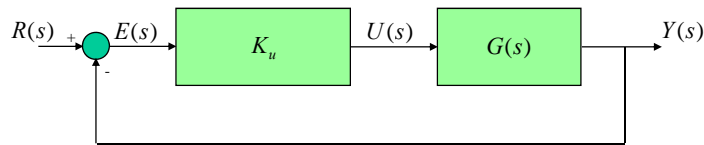

- Increase the constant gain K_u until the response becomes purely oscillatory (no decay – marginally stable – pure imaginary poles)
- Measure the period of oscillation P_u

PID Controller: Ziegler-Nichols Tuning

METHOD 2: Based on limit of stability, ultimate sensitivity method.

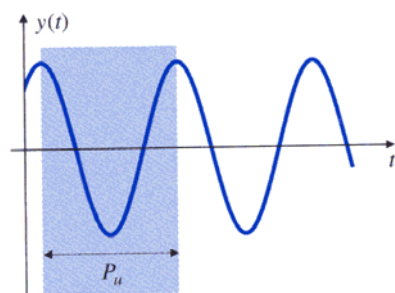

Tuning Table:

$$P: \quad K_p = 0.5K_u$$

$$PD: \quad K_p = 0.45K_u, T_I = \frac{P_u}{1.2}$$

$$PID: \quad K_p = 0.6K_u, T_I = \frac{P_u}{2}, T_D = \frac{P_u}{8}$$

The Tuning Tables are the same if you make:

$$K_u = 2 \frac{\tau}{t_d}, P_u = 4t_d$$

PID Controller: Integrator Windup

Actuator Saturates:

- valve (fully open)
- aircraft rudder (fully deflected)

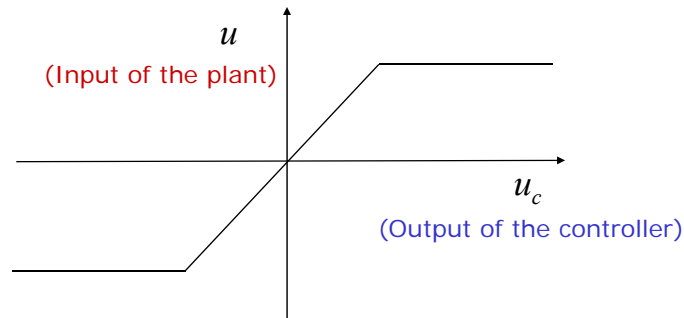

PID Controller: Integrator Windup

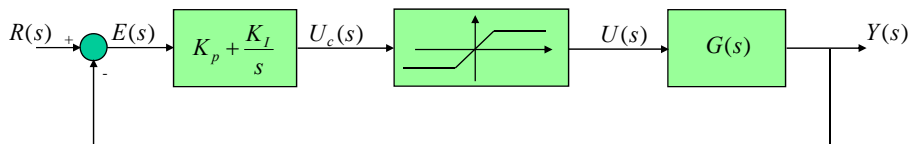

What happens?

- large step input in r
- large e
- large $u_c \rightarrow u$ saturates
- eventually e becomes small
- u_c still large because the integrator is "charged"
- u still at maximum
- y overshoots for a long time

PID Controller: Anti-Windup

Plant without Anti-Windup:

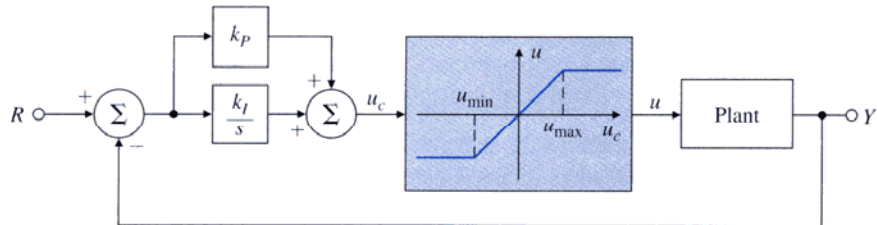

Plant with Anti-Windup:

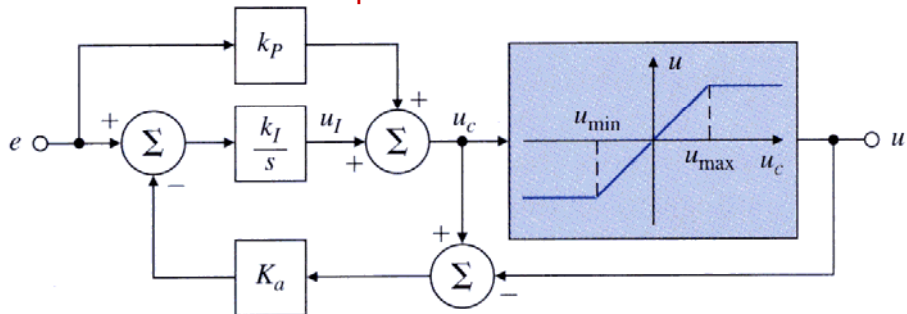

87

PID Controller: Anti-Windup

In saturation, the plant behaves as:

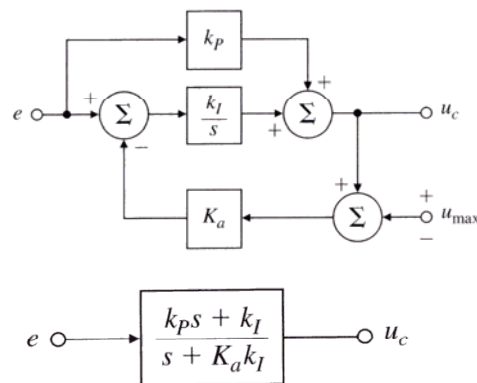

For large K_a , this is a system with very low gain and very fast decay rate, i.e., the integration is turned off.

Steady State Tracking

The Unity Feedback Case

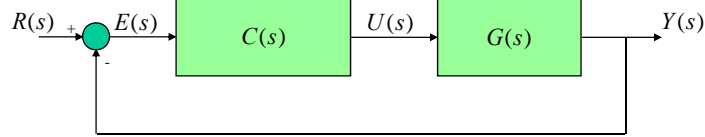

$$\frac{E(s)}{R(s)} = \frac{1}{1 + C(s)G(s)}$$

Test Inputs: $r(t) = \frac{t^k}{k!} 1(t)$ $k=0$: step (position)
 $k=1$: ramp (velocity)
 $k=2$: parabola (acceleration)

$R(s) = \frac{1}{s^{k+1}}$

Steady State Tracking

The Unity Feedback Case

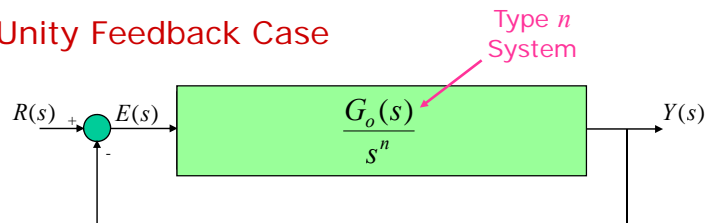

$$C(s)G(s) = \frac{G_o(s)}{s^n}, E(s) = \frac{1}{1 + \frac{G_o(s)}{s^n}} R(s), R(s) = \frac{1}{s^{k+1}}$$

Steady State Error:

Final Value Theorem

$$e_{ss} = \lim_{t \rightarrow \infty} e(t) = \lim_{s \rightarrow 0} sE(s) = \lim_{s \rightarrow 0} s \frac{1}{1 + \frac{G_o(s)}{s^n}} \frac{1}{s^{k+1}} = \lim_{s \rightarrow 0} \frac{s^n}{s^n + G_o(s)} \frac{1}{s^k} = \lim_{s \rightarrow 0} \frac{s^{n-k}}{s^n + G_o(0)}$$

Steady State Tracking

The Unity Feedback Case

Type n
System

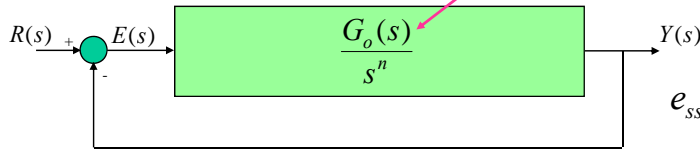

$$e_{ss} = \lim_{s \rightarrow 0} \frac{s^{n-k}}{s^n + G_o(0)}$$

Steady State Error:

Type (n)	Input (k)		
	Step ($k=0$)	Ramp ($k=1$)	Parabola ($k=2$)
Type 0	$\frac{1}{1 + G_o(0)} = \frac{1}{1 + \lim_{s \rightarrow 0} C(s)G(s)} = \frac{1}{1 + K_p}$	∞	∞
Type 1	0	$\frac{1}{G_o(0)} = \frac{1}{\lim_{s \rightarrow 0} sC(s)G(s)} = \frac{1}{K_v}$	∞
Type 2	0	0	$\frac{1}{G_o(0)} = \frac{1}{\lim_{s \rightarrow 0} s^2 C(s)G(s)} = \frac{1}{K_a}$

Steady State Tracking

$$K_p = \lim_{s \rightarrow 0} C(s)G(s) \quad n = 0 \quad \text{Position Constant}$$

$$K_v = \lim_{s \rightarrow 0} sC(s)G(s) \quad n = 1 \quad \text{Velocity Constant}$$

$$K_a = \lim_{s \rightarrow 0} s^2 C(s)G(s) \quad n = 2 \quad \text{Acceleration Constant}$$

n : Degree of the poles of $CG(s)$ at the origin (the number of integrators in the loop with unity gain feedback)

- Applying integral control to a plant with no zeros at the origin makes the system type ≥ 1
- All this is true ONLY for unity feedback systems
- Since in Type 1 systems $e_{ss} = 0$ for any $CG(s)$, we say that the system type is a robust property.

Steady State Tracking

The Unity Feedback Case

$$w(t) = \frac{t^k}{k!} 1(t)$$

$$W(s) = \frac{1}{s^{k+1}}$$

Set $r=0$.
Want $Y(s)/W(s)=0$.

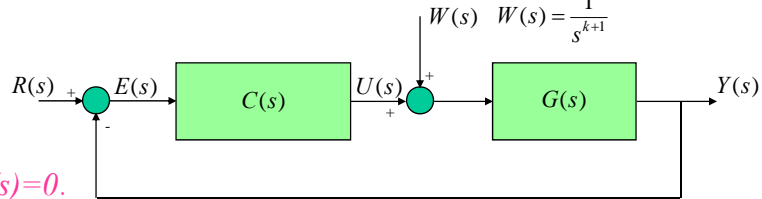

$$\frac{Y(s)}{W(s)} = \frac{G(s)}{1 + C(s)G(s)} = T(s) = s^n T_o(s)$$

Steady State Error: $e=r-y=-y$ Final Value Theorem

$$-e_{ss} = y_{ss} = \lim_{t \rightarrow \infty} y(t) = \lim_{s \rightarrow 0} s Y(s) = \lim_{s \rightarrow 0} s T(s) \frac{1}{s^{k+1}} = \lim_{s \rightarrow 0} T_o(s) \frac{s^n}{s^k}$$

Steady State Tracking

The Unity Feedback Case

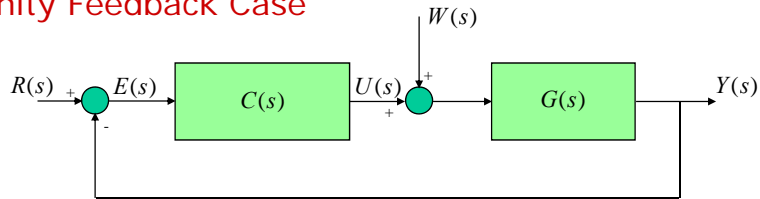

Steady State Output:

Type (n)	Disturbance (k)		
	Step ($k=0$)	Ramp ($k=1$)	Parabola ($k=2$)
Type 0	*	∞	∞
Type 1	0	*	∞
Type 2	0	0	*
			$0 < * < \infty$

Steady State Tracking

Example:

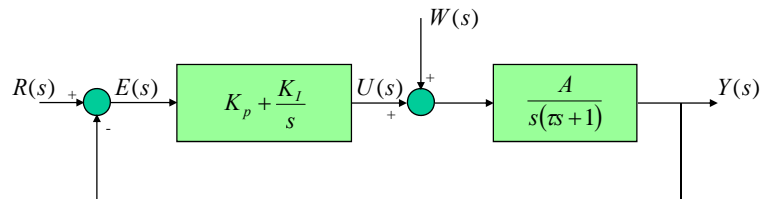

$$K_I \neq 0 \quad \Rightarrow \quad \text{type 1 to } w$$

$$K_p \neq 0, K_I = 0 \quad \Rightarrow \quad \text{type 0 to } w$$

Root Locus

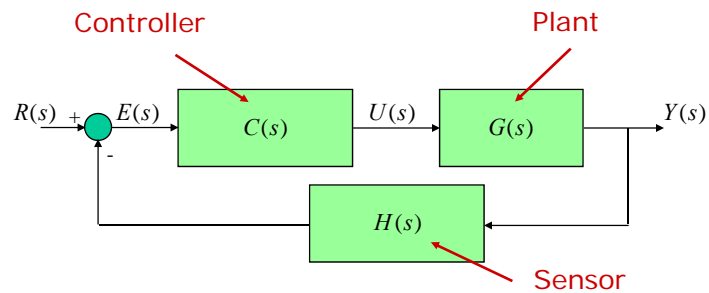

$$C(s) = KD(s) \Rightarrow \frac{Y(s)}{R(s)} = \frac{C(s)G(s)}{1 + C(s)G(s)H(s)} = \frac{C(s)G(s)}{1 + KL(s)}$$

Writing the loop gain as $KL(s)$ we are interested in tracking the closed-loop poles as "gain" K varies

Root Locus

Characteristic Equation:

$$1 + KL(s) = 0$$

The roots (zeros) of the characteristic equation are the closed-loop poles of the feedback system!!!

The closed-loop poles are a function of the "gain" K

Writing the loop gain as

$$L(s) = \frac{b(s)}{a(s)} = \frac{s^m + b_1s^{m-1} + \dots + b_{m-1}s + b_m}{s^n + a_1s^{n-1} + \dots + a_{n-1}s + a_n}$$

The closed loop poles are given indistinctly by the solution of:

$$1 + KL(s) = 0, \quad 1 + K \frac{b(s)}{a(s)} = 0, \quad a(s) + Kb(s) = 0, \quad L(s) = -\frac{1}{K}$$

Root Locus

$$\text{RL} = \text{zeros}\{1 + KL(s)\} = \text{roots}\{\text{den}(L) + K\text{num}(L)\}$$

when K varies from 0 to ∞ (positive Root Locus) or from 0 to $-\infty$ (negative Root Locus)

$$K > 0: L(s) = -\frac{1}{K} \Leftrightarrow \begin{cases} |L(s)| = \frac{1}{K} & \text{Magnitude condition} \\ \angle L(s) = 180^\circ & \text{Phase condition} \end{cases}$$

$$K < 0: L(s) = -\frac{1}{K} \Leftrightarrow \begin{cases} |L(s)| = \frac{1}{K} & \text{Magnitude condition} \\ \angle L(s) = 0^\circ & \text{Phase condition} \end{cases}$$

Root Locus by Characteristic Equation Solution

Example:

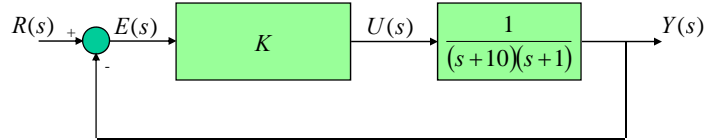

$$\frac{Y(s)}{R(s)} = \frac{K}{s^2 + 11s + (10 + K)}$$

Closed-loop poles: $1 + L(s) = 0 \Leftrightarrow s^2 + 11s + (10 + K) = 0$

$$s = -5.5 \pm \frac{\sqrt{81 - 4K}}{2}$$

$s = -1, -10$	$K = 0$
$s = -5.5 \pm \frac{\sqrt{81 - 4K}}{2}$	$81 - 4K > 0$
$s = -5.5$	$81 - 4K = 0$
$s = -5.5 \pm i \frac{\sqrt{4K - 81}}{2}$	$81 - 4K < 0$

Root Locus by Characteristic Equation Solution

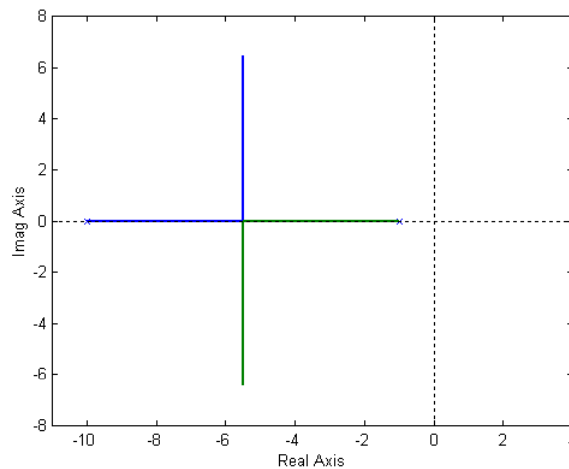

We need a systematic approach to plot the closed-loop poles as function of the gain $K \rightarrow$ ROOT LOCUS

Root Locus by Phase Condition

Example:

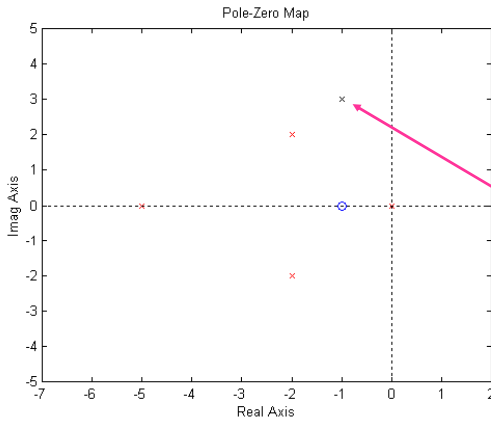
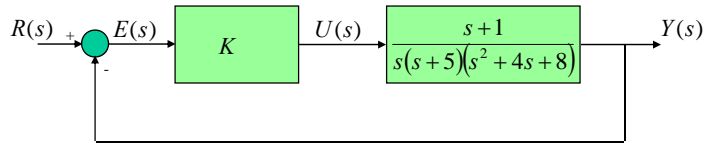

$$L(s) = \frac{s+1}{s(s+5)(s^2+4s+8)}$$

$$= \frac{s+1}{s(s+5)(s+2+2i)(s+2-2i)}$$

$$s_o = -1 + 3i$$

belongs to the locus?

Root Locus by Phase Condition

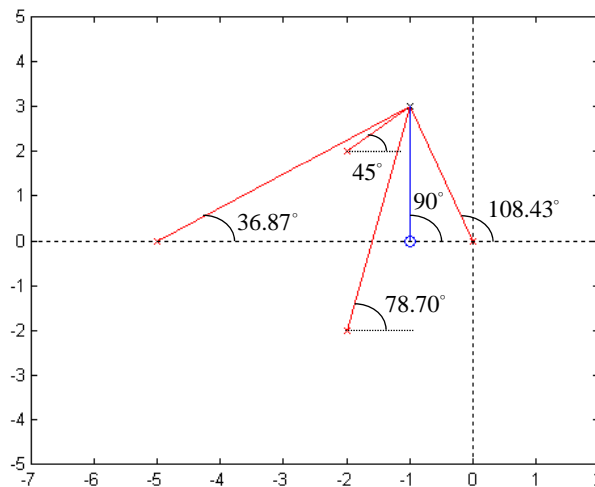

$$90^\circ - [108.43^\circ + 36.87^\circ + 45^\circ + 78.70^\circ] \approx -180^\circ \Rightarrow s_o = -1 + 3i \text{ belongs to the locus!}$$

Note: Check code lecture09_a.m

Root Locus by Phase Condition

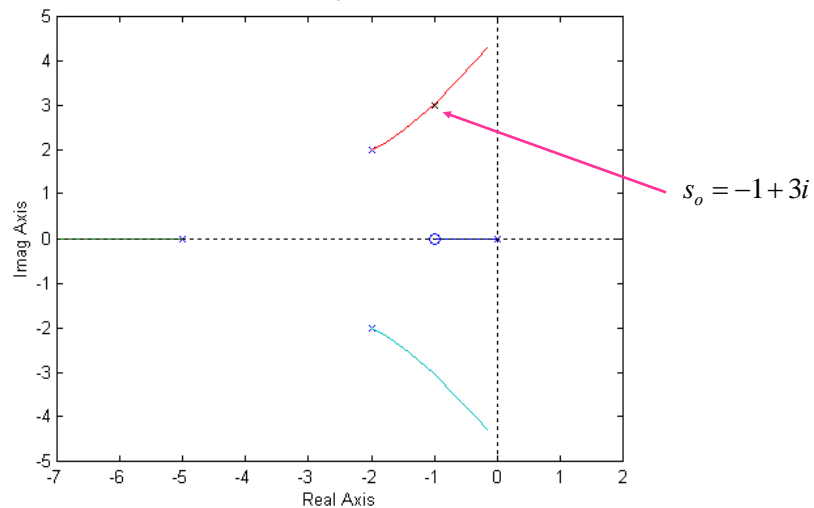

We need a systematic approach to plot the closed-loop poles as function of the gain $K \rightarrow$ ROOT LOCUS

Root Locus

RL = zeros $\{1 + KL(s)\}$ = roots $\{\text{den}(L) + K\text{num}(L)\}$
 when K varies from 0 to ∞ (positive Root Locus) or
 from 0 to $-\infty$ (negative Root Locus)

$$1 + KL(s) = 0 \Leftrightarrow L(s) = -\frac{1}{K} \Leftrightarrow a(s) + Kb(s) = 0$$

Basic Properties:

- Number of branches = number of open-loop poles
- RL begins at open-loop poles

$$K = 0 \Rightarrow a(s) = 0$$

- RL ends at open-loop zeros or asymptotes

$$K = \infty \Rightarrow L(s) = 0 \Leftrightarrow \begin{cases} b(s) = 0 \\ s \rightarrow \infty (n - m > 0) \end{cases}$$

- RL symmetrical about Re-axis

Root Locus

Rule 1: The n branches of the locus start at the poles of $L(s)$ and m of these branches end on the zeros of $L(s)$.

n : order of the denominator of $L(s)$

m : order of the numerator of $L(s)$

Rule 2: The locus is on the real axis to the left of and odd number of poles and zeros.

In other words, an interval on the real axis belongs to the root locus if the total number of poles and zeros to the right is odd.

This rule comes from the phase condition!!!

Root Locus

Rule 3: As $K \rightarrow \infty$, m of the closed-loop poles approach the open-loop zeros, and $n-m$ of them approach $n-m$ asymptotes with angles

$$\phi_l = (2l + 1) \frac{\pi}{n - m}, \quad l = 0, 1, \dots, n - m - 1$$

and centered at

$$\alpha = \frac{b_1 - a_1}{n - m} = \frac{\sum \text{poles} - \sum \text{zeros}}{n - m}, \quad l = 0, 1, \dots, n - m - 1$$

Root Locus

Rule 4: The locus crosses the $j\omega$ axis (loses stability) where the Routh criterion shows a transition from roots in the left half-plane to roots in the right-half plane.

Example:

$$G(s) = \frac{s+5}{s(s^2+4s+5)}$$

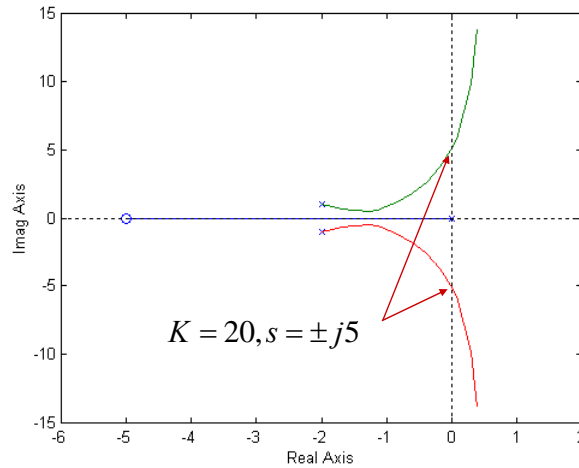

Root Locus

Example: $G(s) = \frac{s+1}{s^4+3s^3+7s^2+6s+4}$

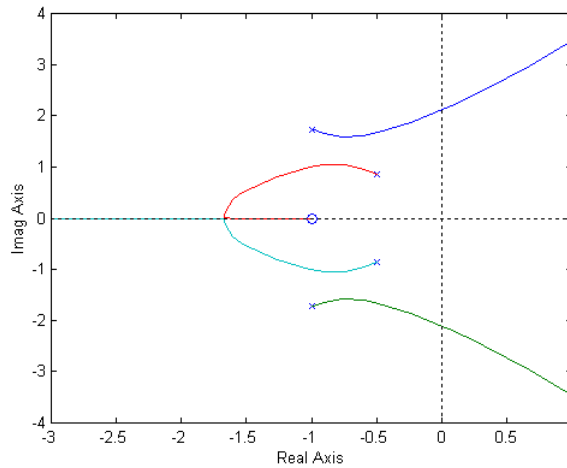

Root Locus

Design dangers revealed by the Root Locus:

- **High relative degree:** For $n-m \geq 3$ we have closed loop instability due to asymptotes.

$$G(s) = \frac{s+1}{s^4 + 3s^3 + 7s^2 + 6s + 4}$$

- **Nonminimum phase zeros:** They attract closed loop poles into the RHP

$$G(s) = \frac{s-1}{s^2 + s + 1}$$

Note: Check code lecture09_b.m

Root Locus

Viète's formula:

When the relative degree $n-m \geq 2$, the sum of the closed loop poles is constant

$$a_1 = -\sum \text{closed loop poles}$$

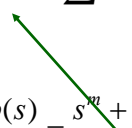
$$L(s) = \frac{b(s)}{a(s)} = \frac{s^m + b_1 s^{m-1} + \dots + b_{m-1} s + b_m}{s^n + a_1 s^{n-1} + \dots + a_{n-1} s + a_n}$$

Phase and Magnitude of a Transfer Function

$$G(s) = \frac{b_m s^m + b_{m-1} s^{m-1} + \dots + b_1 s + b_0}{s^n + a_{n-1} s^{n-1} + \dots + a_1 s + a_0}$$

$$G(s) = K \frac{(s - z_1)(s - z_2) \dots (s - z_m)}{(s - p_1)(s - p_2) \dots (s - p_n)}$$

The factors K , $(s - z_j)$ and $(s - p_k)$ are complex numbers:

$$(s - z_j) = r_j^z e^{i\phi_j^z}, \quad j = 1 \dots m$$

$$(s - p_k) = r_k^p e^{i\phi_k^p}, \quad k = 1 \dots p$$

$$K = |K| e^{i\phi^K}$$

$$G(s) = |K| e^{i\phi^K} \frac{r_1^z e^{i\phi_1^z} r_2^z e^{i\phi_2^z} \dots r_m^z e^{i\phi_m^z}}{r_1^p e^{i\phi_1^p} r_2^p e^{i\phi_2^p} \dots r_n^p e^{i\phi_n^p}}$$

Phase and Magnitude of a Transfer Function

$$\begin{aligned} G(s) &= |K| e^{i\phi^K} \frac{r_1^z e^{i\phi_1^z} r_2^z e^{i\phi_2^z} \dots r_m^z e^{i\phi_m^z}}{r_1^p e^{i\phi_1^p} r_2^p e^{i\phi_2^p} \dots r_n^p e^{i\phi_n^p}} \\ &= |K| e^{i\phi^K} \frac{r_1^z r_2^z \dots r_m^z e^{i(\phi_1^z + \phi_2^z + \dots + \phi_m^z)}}{r_1^p r_2^p \dots r_n^p e^{i(\phi_1^p + \phi_2^p + \dots + \phi_n^p)}} \\ &= |K| \frac{r_1^z r_2^z \dots r_m^z}{r_1^p r_2^p \dots r_n^p} e^{i[\phi^K + (\phi_1^z + \phi_2^z + \dots + \phi_m^z) - (\phi_1^p + \phi_2^p + \dots + \phi_n^p)]} \end{aligned}$$

Now it is easy to give the phase and magnitude of the transfer function:

$$|G(s)| = |K| \frac{r_1^z r_2^z \dots r_m^z}{r_1^p r_2^p \dots r_n^p},$$

$$\angle G(s) = \phi^K + (\phi_1^z + \phi_2^z + \dots + \phi_m^z) - (\phi_1^p + \phi_2^p + \dots + \phi_n^p)$$

Phase and Magnitude of a Transfer Function

Example:
$$G(s) = \frac{(s + 6.735)}{(s + 1)(s + 5)(s + 20)}$$

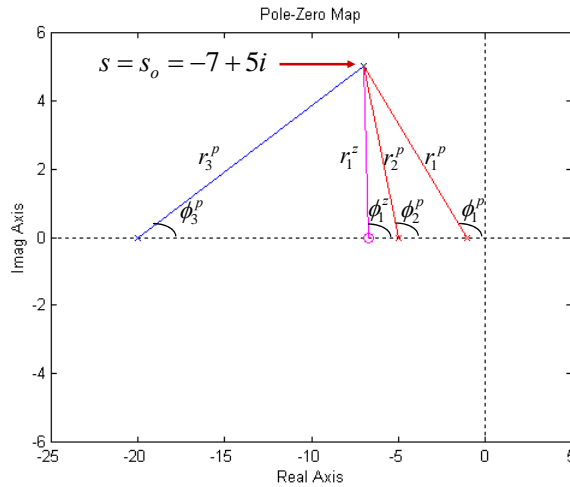

$$|G(s)| = \frac{r_1^z}{r_1^p r_2^p r_3^p}$$

$$\angle G(s) = \phi_1^z - (\phi_1^p + \phi_2^p + \phi_3^p)$$

Root Locus- Magnitude and Phase Conditions

RL = zeros{1 + KL(s)} = roots{den(L) + Knum(L)}
 when K varies from 0 to ∞ (positive Root Locus) or
 from 0 to -∞ (negative Root Locus)

$$L(s) = K_p \frac{(s - z_1)(s - z_2) \cdots (s - z_m)}{(s - p_1)(s - p_2) \cdots (s - p_n)} = |K_p| \frac{r_1^z r_2^z \cdots r_m^z}{r_1^p r_2^p \cdots r_n^p} e^{i[\phi^{K_p} + (\phi_1^z + \phi_2^z + \cdots + \phi_m^z) - (\phi_1^p + \phi_2^p + \cdots + \phi_n^p)]}$$

$$K > 0: L(s) = -\frac{1}{K} \Leftrightarrow |L(s)| = |K_p| \frac{r_1^z r_2^z \cdots r_m^z}{r_1^p r_2^p \cdots r_n^p} = \frac{1}{K}$$

$$\angle L(s) = \phi^{K_p} + (\phi_1^z + \phi_2^z + \cdots + \phi_m^z) - (\phi_1^p + \phi_2^p + \cdots + \phi_n^p) = 180^\circ$$

$$K < 0: L(s) = -\frac{1}{K} \Leftrightarrow |L(s)| = |K_p| \frac{r_1^z r_2^z \cdots r_m^z}{r_1^p r_2^p \cdots r_n^p} = -\frac{1}{K}$$

$$\angle L(s) = \phi^{K_p} + (\phi_1^z + \phi_2^z + \cdots + \phi_m^z) - (\phi_1^p + \phi_2^p + \cdots + \phi_n^p) = 0^\circ$$

Root Locus

Selecting K for desired closed loop poles on Root Locus:

If s_o belongs to the root locus, it must satisfy the characteristic equation for some value of K

$$L(s_o) = -\frac{1}{K}$$

Then we can obtain K as

$$K = -\frac{1}{L(s_o)}$$

$$K = \frac{1}{|L(s_o)|}$$

Root Locus

Example: $L(s) = G(s) = \frac{1}{(s+1)(s+5)}$

$$\begin{aligned} s_o = -3 + i4 \Rightarrow K &= \frac{1}{|L(s_o)|} = |s_o + 1| |s_o + 5| = |-3 + i4 + 1| |-3 + i4 + 5| \\ &= \sqrt{(-2)^2 + 4^2} \sqrt{(2)^2 + 4^2} = 20 \end{aligned}$$

Using MATLAB:

```
sys=tf(1,poly([-1 -5]))  
so=-3+4i  
[K,POLES]=rlocfind(sys,so)
```

Root Locus

Example:

$$L(s) = G(s) = \frac{1}{(s+1)(s+5)}$$

$$s_o = -7 + i5$$

⇓

$$K = \frac{1}{|L(s_o)|} = 42.06$$

$$s_o = -7 + i5$$

$$s_o = -3 + i4$$

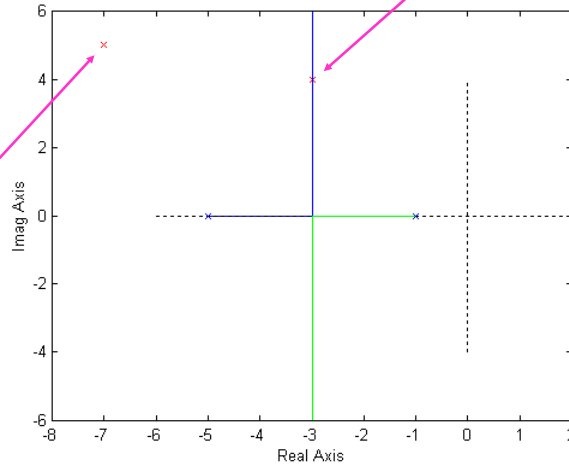

When we use the absolute value formula we are assuming that the point belongs to the Root Locus!

Root Locus - Compensators

Example:

$$L(s) = G(s) = \frac{1}{(s+1)(s+5)}$$

Can we place the closed loop pole at $s_o = -7 + i5$ only varying K ?

NO. We need a **COMPENSATOR**.

$$L(s) = G(s) = \frac{1}{(s+1)(s+5)}$$

$$L(s) = D(s)G(s) = (s+10) \frac{1}{(s+1)(s+5)}$$

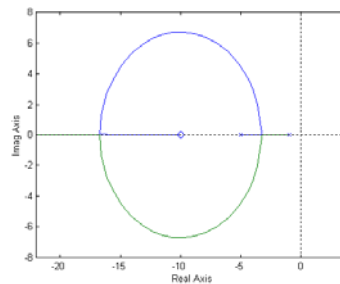
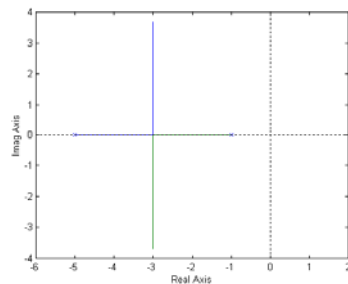

The zero attracts the locus!!!

Root Locus – Phase lead compensator

Pure derivative control is not normally practical because of the amplification of the noise due to the differentiation and must be approximated:

$$D(s) = \frac{s+z}{s+p}, \quad p > z \quad \text{Phase lead COMPENSATOR}$$

When we study frequency response we will understand why we call "Phase Lead" to this compensator.

$$L(s) = D(s)G(s) = \frac{s+z}{s+p} \frac{1}{(s+1)(s+5)}, \quad p > z$$

How do we choose z and p to place the closed loop pole at $s_o = -7+5i$?

Root Locus – Phase lead compensator

Example:

$$L(s) = D(s)G(s) = \frac{s+z}{s+p} \frac{1}{(s+1)(s+5)}, \quad p < z$$

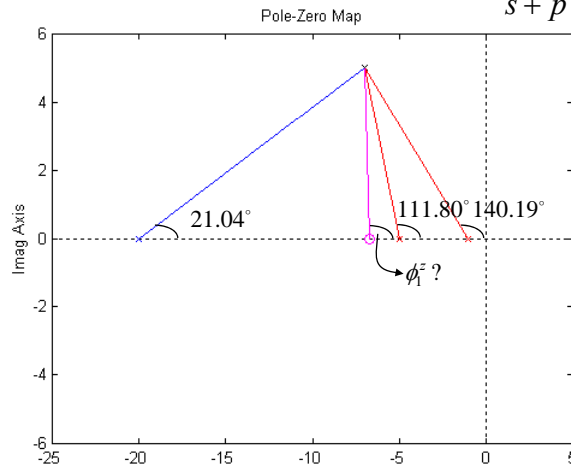

Phase lead COMPENSATOR

$$\angle L(s) = \phi^K_p + (\phi_1^z + \phi_2^z + \dots + \phi_m^z) - (\phi_1^p + \phi_2^p + \dots + \phi_n^p) = 180^\circ$$

$$\phi_1^z = 180^\circ + 140.19^\circ + 111.80^\circ + 21.04^\circ = 453.03^\circ = 93.03^\circ \Rightarrow z = -6.735$$

Root Locus – Phase lead compensator

Example:

$$L(s) = D(s)G(s) = \frac{s + 6.735}{s + 20} \frac{1}{(s + 1)(s + 5)}$$

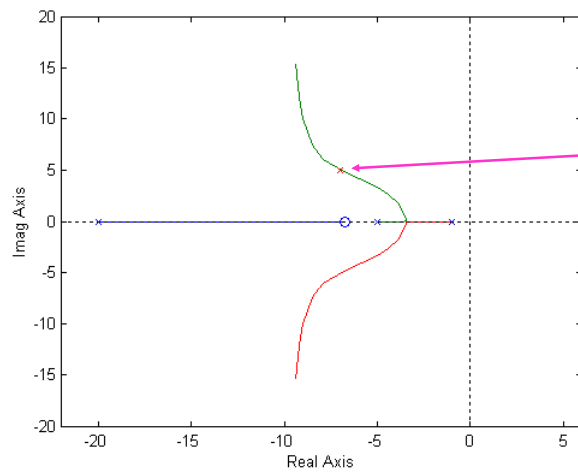

Phase lead
COMPENSATOR

$$s_o = -7 + i5$$

$$K = 117$$

Root Locus – Phase lead compensator

Selecting z and p is a trial and error procedure. In general:

- The zero is placed in the neighborhood of the closed-loop natural frequency, as determined by rise-time or settling time requirements.
- The pole is placed at a distance 5 to 20 times the value of the zero location. The pole is fast enough to avoid modifying the dominant pole behavior.

The exact position of the pole p is a compromise between:

- Noise suppression (we want a small value for p)
- Compensation effectiveness (we want large value for p)

Root Locus – Phase lag compensator

Example:
$$L(s) = D(s)G(s) = \frac{s + 6.735}{s + 20} \frac{1}{(s + 1)(s + 5)}$$

$$K_p = \lim_{s \rightarrow 0} L(s) = \lim_{s \rightarrow 0} D(s)G(s) = \lim_{s \rightarrow 0} \frac{s + 6.735}{s + 20} \frac{1}{(s + 1)(s + 5)} = 6.735 \times 10^{-2}$$

What can we do to increase K_p ? Suppose we want $K_p=10$.

$$L(s) = D(s)G(s) = \frac{s + z}{s + p} \frac{s + 6.735}{s + 20} \frac{1}{(s + 1)(s + 5)}, \quad p < z$$

Phase lag
COMPENSATOR

We choose:
$$\frac{z}{p} = \frac{1}{6.735} \times 10^3 = 148.48$$

Root Locus – Phase lag compensator

Example:
$$L(s) = D(s)G(s) = \frac{s + 0.14848}{s + 0.001} \frac{s + 6.735}{s + 20} \frac{1}{(s + 1)(s + 5)}$$

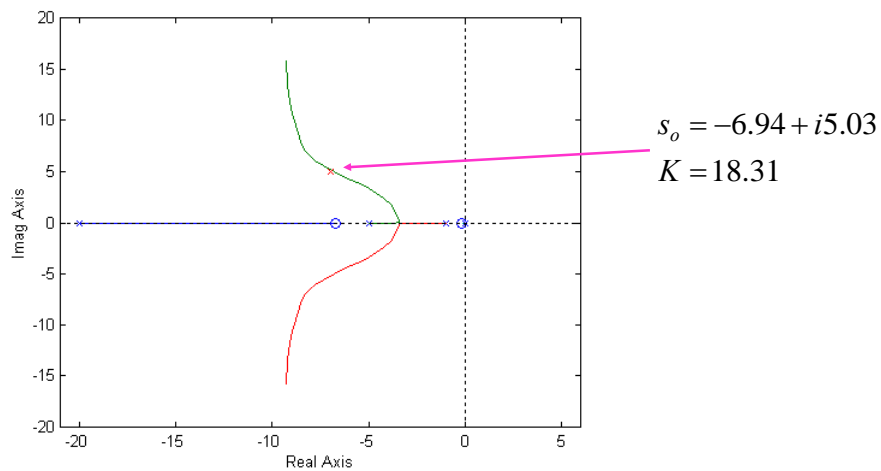

Root Locus – Phase lag compensator

Selecting z and p is a trial and error procedure. In general:

- The ratio zero/pole is chosen based on the error constant specification.
- We pick z and p small to avoid affecting the dominant dynamic of the system (to avoid modifying the part of the locus representing the dominant dynamics)
- Slow transient due to the small p is almost cancelled by a small z . The ratio zero/pole cannot be very big.

The exact position of z and p is a compromise between:

- Steady state error (we want a large value for z/p)
- The transient response (we want the pole p placed far from the origin)

Root Locus - Compensators

Phase lead compensator: $D(s) = \frac{s+z}{s+p}, \quad z < p$

Phase lag compensator: $D(s) = \frac{s+z}{s+p}, \quad z > p$

We will see why we call “phase lead” and “phase lag” to these compensators when we study frequency response

Frequency Response

- We now know how to analyze and design systems via s-domain methods which yield dynamical information
 - The responses are described by the exponential modes
 - The modes are determined by the poles of the response Laplace Transform
- We next will look at describing cct performance via frequency response methods
 - This guides us in specifying the system pole and zero positions

Sinusoidal Steady-State Response

Consider a **stable transfer** function with a **sinusoidal input**:

$$u(t) = A \cos(\omega t) \Leftrightarrow U(s) = \frac{A\omega}{s^2 + \omega^2}$$

The Laplace Transform of the response has poles

- Where the natural modes lie
 - These are in the open left half plane $\text{Re}(s) < 0$
- At the input modes $s = +j\omega$ and $s = -j\omega$

$$Y(s) = G(s)U(s) = K \frac{(s - z_1)(s - z_2) \cdots (s - z_m)}{(s - p_1)(s - p_2) \cdots (s - p_n)} \frac{A\omega}{(s^2 + \omega^2)}$$

Only the response due to the poles on the imaginary axis remains after a sufficiently long time

This is the sinusoidal steady-state response

Sinusoidal Steady-State Response

- Input** $u(t) = A \cos(\omega t + \phi) = A \cos \omega t \sin \phi - A \sin \omega t \cos \phi$

- Transform** $U(s) = -A \cos \phi \frac{s}{s^2 + \omega^2} + A \sin \phi \frac{\omega}{s^2 + \omega^2}$

- Response Transform**

$$Y(s) = G(s)U(s) = \underbrace{\frac{k}{s - j\omega} + \frac{k^*}{s + j\omega}}_{\text{forced response}} + \underbrace{\frac{k_1}{s - p_1} + \frac{k_2}{s - p_2} + \dots + \frac{k_N}{s - p_N}}_{\text{natural response}}$$

- Response Signal**

$$y(t) = \underbrace{ke^{j\omega t} + k^* e^{-j\omega t}}_{\text{forced response}} + \underbrace{k_1 e^{p_1 t} + k_2 e^{p_2 t} + \dots + k_N e^{p_N t}}_{\text{natural response}}$$

- Sinusoidal Steady State Response**

$$y_{SS}(t) = ke^{j\omega t} + k^* e^{-j\omega t}$$

$t \rightarrow \infty$
↘
0

Sinusoidal Steady-State Response

- Calculating the SSS response to** $u(t) = A \cos(\omega t + \phi)$

- Residue calculation**

$$\begin{aligned} k &= \lim_{s \rightarrow j\omega} [(s - j\omega)Y(s)] = \lim_{s \rightarrow j\omega} [(s - j\omega)G(s)U(s)] \\ &= \lim_{s \rightarrow j\omega} \left[G(s)(s - j\omega)A \frac{s \cos \phi - \omega \sin \phi}{(s - j\omega)(s + j\omega)} \right] = G(j\omega)A \left[\frac{j\omega \cos \phi - \omega \sin \phi}{2j\omega} \right] \\ &= AG(j\omega) \frac{1}{2} e^{j\phi} = \frac{1}{2} A |G(j\omega)| e^{j(\phi + \angle G(j\omega))} \end{aligned}$$

- Signal calculation**

$$\begin{aligned} y_{ss}(t) &= L^{-1} \left\{ \frac{k}{s - j\omega} + \frac{k^*}{s + j\omega} \right\} \\ &= |k| e^{j\angle K} e^{j\omega t} + |k| e^{-j\angle K} e^{-j\omega t} \\ &= 2|k| \cos(\omega t + \angle K) \end{aligned}$$

$$y_{ss}(t) = A |G(j\omega)| \cos(\omega t + \phi + \angle G(j\omega))$$

Sinusoidal Steady-State Response

- **Response to** $u(t) = A \cos(\omega t + \phi)$
- **is** $y_{ss} = |G(j\omega)| A \cos(\omega t + \phi + \angle G(j\omega))$
 - Output frequency = input frequency
 - Output amplitude = input amplitude $\times |G(j\omega)|$
 - Output phase = input phase $+\angle G(j\omega)$
- **The Frequency Response of the transfer function $G(s)$ is given by its evaluation as a function of a complex variable at $s=j\omega$**
 - We speak of the amplitude response and of the phase response
 - They cannot independently be varied
 - » Bode's relations of analytic function theory

Frequency Response

- Find the steady state output for $v_1(t) = A \cos(\omega t + \phi)$

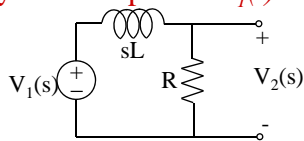

- **Compute the s-domain transfer function $T(s)$**
 - Voltage divider $T(s) = \frac{R}{sL + R}$
- **Compute the frequency response**

$$|T(j\omega)| = \frac{R}{\sqrt{R^2 + (\omega L)^2}}, \quad \angle T(j\omega) = -\tan^{-1}\left(\frac{\omega L}{R}\right)$$
- **Compute the steady state output**

$$v_{2SS}(t) = \frac{AR}{\sqrt{R^2 + (\omega L)^2}} \cos\left[\omega t + \phi - \tan^{-1}(\omega L / R)\right]$$

Bode Diagrams

- Log-log plot of $\text{mag}(T)$, log-linear plot of $\text{arg}(T)$ versus ω

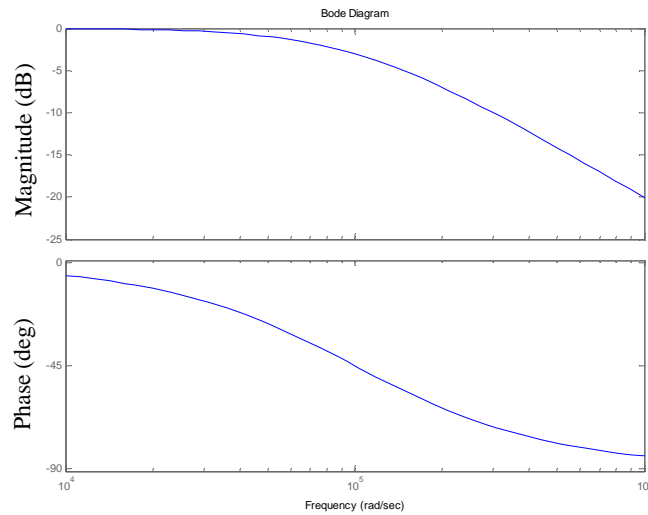

Frequency Response

$$u(t) = A \cos(\omega t + \phi) \longrightarrow \boxed{G(s)} \longrightarrow y_{ss} = |G(j\omega)| A \cos(\omega t + \phi + \angle G(j\omega))$$

- After a transient, the output settles to a sinusoid with an amplitude magnified by $|G(j\omega)|$ and phase shifted by $\angle G(j\omega)$.
- Since all signals can be represented by sinusoids (Fourier series and transform), the quantities $|G(j\omega)|$ and $\angle G(j\omega)$ are extremely important.
- Bode developed methods for quickly finding $|G(j\omega)|$ and $\angle G(j\omega)$ for a given $G(s)$ and for using them in control design.

Frequency Response

- Find the steady state output for $v_1(t) = A \cos(\omega t + \phi)$

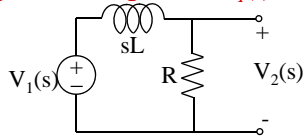

- Compute the s-domain transfer function $T(s)$

– Voltage divider $T(s) = \frac{R}{sL + R}$

- Compute the frequency response

$$|T(j\omega)| = \frac{R}{\sqrt{R^2 + (\omega L)^2}}, \quad \angle T(j\omega) = -\tan^{-1}\left(\frac{\omega L}{R}\right)$$

- Compute the steady state output

$$v_{2SS}(t) = \frac{AR}{\sqrt{R^2 + (\omega L)^2}} \cos\left[\omega t + \phi - \tan^{-1}(\omega L / R)\right]$$

Frequency Response - Bode Diagrams

- Log-log plot of $\text{mag}(T)$, log-linear plot of $\text{arg}(T)$ versus ω

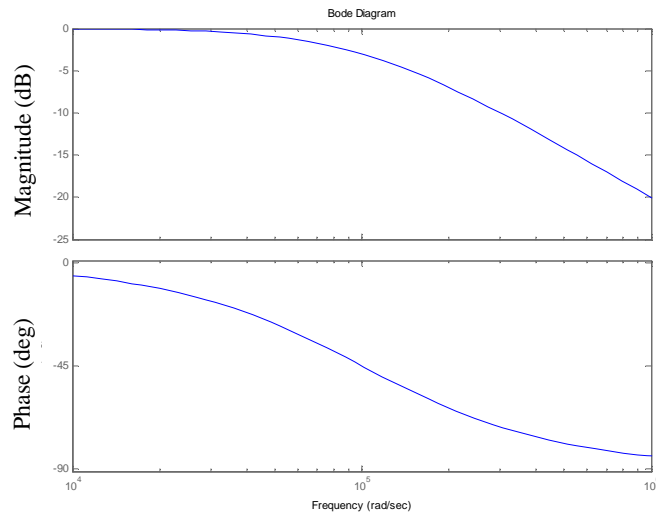

$[\omega] = \text{rad/sec}, \quad \omega = 2\pi f, \quad [f] = \text{Hz}$

Bode Diagrams

$$G(s) = K \frac{(s - z_1)(s - z_2) \cdots (s - z_m)}{(s - p_1)(s - p_2) \cdots (s - p_n)}$$



$$G(s) = |K| \frac{r_1^z r_2^z \cdots r_m^z}{r_1^p r_2^p \cdots r_n^p} e^{i[\phi^K + (\phi_1^z + \phi_2^z + \cdots + \phi_m^z) - (\phi_1^p + \phi_2^p + \cdots + \phi_n^p)]}$$

The magnitude and phase of $G(s)$ when $s=j\omega$ is given by:

$$|G(j\omega)| = |K| \frac{r_1^z r_2^z \cdots r_m^z}{r_1^p r_2^p \cdots r_n^p},$$

Nonlinear in the magnitudes

$$\angle G(j\omega) = \phi^K + (\phi_1^z + \phi_2^z + \cdots + \phi_m^z) - (\phi_1^p + \phi_2^p + \cdots + \phi_n^p)$$

Linear in the phases

Bode Diagrams

Why do we express $|G(j\omega)|$ in decibels?

$$|G(j\omega)|_{dB} = 20 \log |G(j\omega)|$$

$$|G(j\omega)| = |K| \frac{r_1^z r_2^z \cdots r_m^z}{r_1^p r_2^p \cdots r_n^p} \Rightarrow |G(j\omega)|_{dB} = ?$$

By properties of the logarithm we can write:

$$20 \log |G(s)| = 20 \log |K| + (20 \log r_1^z + 20 \log r_2^z + \cdots + 20 \log r_m^z) - (20 \log r_1^p + 20 \log r_2^p + \cdots + 20 \log r_n^p)$$

The magnitude and phase of $G(s)$ when $s=j\omega$ is given by:

$$|G(s)|_{dB} = |K|_{dB} + (r_1^z|_{dB} + r_2^z|_{dB} + \cdots + r_m^z|_{dB}) - (r_1^p|_{dB} + r_2^p|_{dB} + \cdots + r_n^p|_{dB})$$

Linear in the magnitudes (dB)

$$\angle G(s) = \phi^K + (\phi_1^z + \phi_2^z + \cdots + \phi_m^z) - (\phi_1^p + \phi_2^p + \cdots + \phi_n^p)$$

Linear in the phases

Bode Diagrams

Why do we use a logarithmic scale? Let's have a look at our example:

$$T(s) = \frac{R}{sL + R} \Rightarrow |T(j\omega)| = \frac{R}{\sqrt{R^2 + (\omega L)^2}} = \frac{1}{\sqrt{1 + \left(\frac{\omega L}{R}\right)^2}}$$

Expressing the magnitude in dB:

$$|T(j\omega)|_{dB} = 20\log 1 - 20\log \sqrt{1 + \left(\frac{\omega L}{R}\right)^2} = -10\log \left[1 + \left(\frac{\omega L}{R}\right)^2 \right]$$

Asymptotic behavior:

$$\omega \rightarrow 0: |T(j\omega)|_{dB} \rightarrow 0$$

$$\omega \rightarrow \infty: |T(j\omega)|_{dB} \rightarrow -20\log\left(\frac{\omega}{R/L}\right) = 20\log(R/L) - 20\log\omega = \frac{R}{L}_{dB} - 20\log\omega$$

LINEAR FUNCTION in $\log\omega$!!! We plot $|G(j\omega)|_{dB}$ as a function of $\log\omega$.

Bode Diagrams

Decade: Any frequency range whose end points have a 10:1 ratio

A cutoff frequency occurs when the gain is reduced from its maximum passband value by a factor $1/\sqrt{2}$:

$$20\log\left(\frac{1}{\sqrt{2}}|T|_{MAX}\right) = 20\log|T|_{MAX} - 20\log\sqrt{2} \approx 20\log|T|_{MAX} - 3dB$$

Bandwidth: frequency range spanned by the gain passband

Let's have a look at our example:

$$|T(j\omega)| = \frac{1}{\sqrt{1 + \left(\frac{\omega L}{R}\right)^2}} \Rightarrow \begin{cases} \omega = 0 & |T(j\omega)| = 1 \\ \omega = R/L & |T(j\omega)| = 1/\sqrt{2} \end{cases}$$

This is a low-pass filter!!! Passband gain=1, Cutoff frequency=R/L
The Bandwidth is R/L!

General Transfer Function (Bode Form)

$$G(j\omega) = K_o (j\omega)^m (j\omega\tau + 1)^n \left[\left(\frac{j\omega}{\omega_n} \right)^2 + 2\zeta \frac{j\omega}{\omega_n} + 1 \right]^q$$

The **magnitude (dB)** (**phase**) is the sum of the **magnitudes (dB)** (**phases**) of each one of the terms. We learn how to plot each term, we learn how to plot the whole magnitude and phase Bode Plot.

Classes of terms:

- 1- $G(j\omega) = K_o$
- 2- $G(j\omega) = (j\omega)^m$
- 3- $G(j\omega) = (j\omega\tau + 1)^n$
- 4- $G(j\omega) = \left[\left(\frac{j\omega}{\omega_n} \right)^2 + 2\zeta \frac{j\omega}{\omega_n} + 1 \right]^q$

General Transfer Function: DC gain

$$G(j\omega) = K_o$$

Magnitude and Phase: $|G(j\omega)|_{dB} = 20\log|K_o|$

$$\angle G(j\omega) = \begin{cases} 0 & \text{if } K_o > 0 \\ \pm \pi & \text{if } K_o < 0 \end{cases}$$

$$G(s) = -10$$

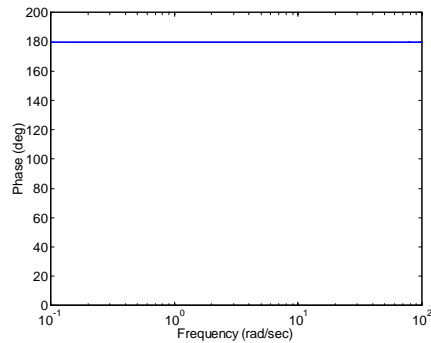
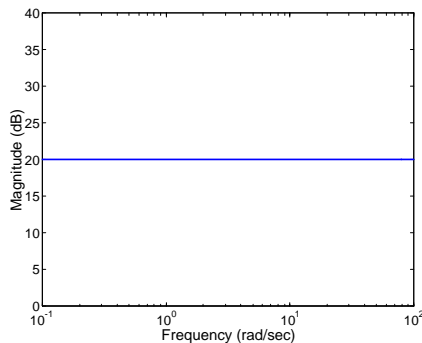

General Transfer Function: Poles/zeros at origin

$$G(j\omega) = (j\omega)^m$$

Magnitude and Phase: $|G(j\omega)|_{dB} = m \cdot 20 \log \omega$

$$m = -1, G(s) = \frac{1}{s} \quad \angle G(j\omega) = m \frac{\pi}{2}$$

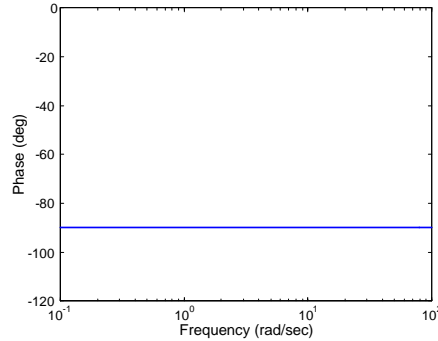
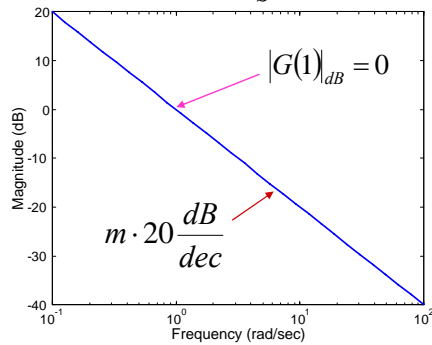

Classical Control – Prof. Eugenio Schuster – Lehigh University

143

General Transfer Function: Real poles/zeros

$$G(j\omega) = (j\omega\tau + 1)^n$$

Magnitude and Phase:

$$|G(j\omega)|_{dB} = n \cdot 10 \log(\omega^2 \tau^2 + 1)$$

$$\angle G(j\omega) = n \tan^{-1}(\omega\tau)$$

Asymptotic behavior:

$$|G(j\omega)|_{dB} \xrightarrow{\omega \ll 1/\tau} 0$$

$$\angle G(j\omega) \xrightarrow{\omega \ll 1/\tau} 0^\circ$$

$$|G(j\omega)|_{dB} \xrightarrow{\omega \gg 1/\tau} n \cdot \tau |_{dB} + n \cdot 20 \log \omega$$

$$\angle G(j\omega) \xrightarrow{\omega \gg 1/\tau} n \cdot 90^\circ$$

Classical Control – Prof. Eugenio Schuster – Lehigh University

144

General Transfer Function: Real poles/zeros

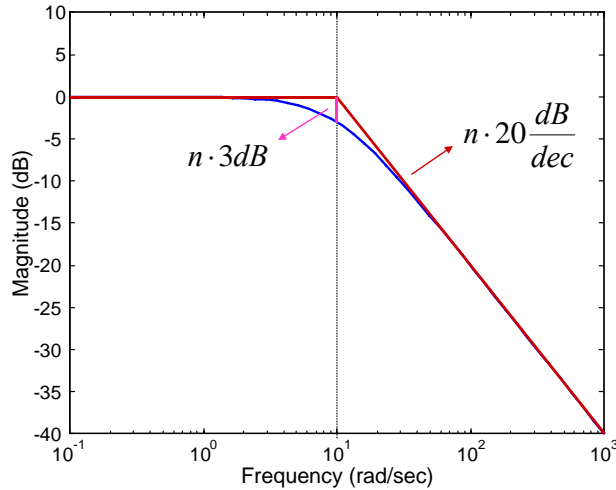

$$n = -1, \tau = 1/10$$

$$G(s) = \frac{1}{\frac{s}{10} + 1}$$

$$|G(j0)|_{dB} = 0dB$$

$$|G(j1/\tau)|_{dB} = n \cdot 3dB$$

$$|G(\infty)|_{dB} = \text{sgn}(n)\infty dB$$

General Transfer Function: Real poles/zeros

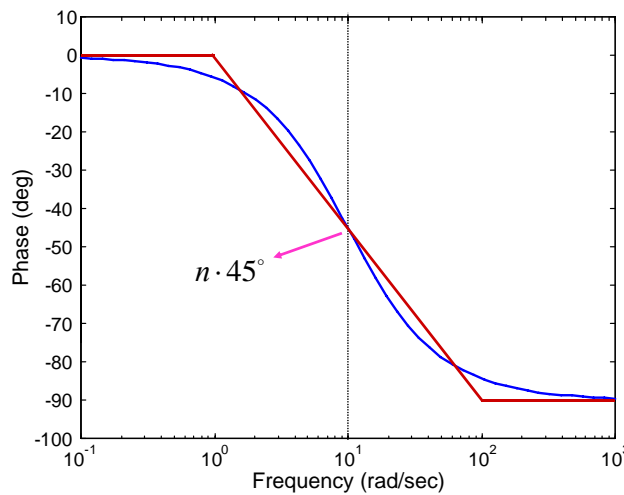

$$n = -1, \tau = 1/10$$

$$G(s) = \frac{1}{\frac{s}{10} + 1}$$

$$\angle G(j0) = 0^\circ$$

$$\angle G(j1/\tau) = n \cdot 45^\circ$$

$$\angle G(j\infty) = n \cdot 90^\circ$$

General Transfer Function: Complex poles/zeros

$$G(j\omega) = \left[\left(\frac{j\omega}{\omega_n} \right)^2 + 2\zeta \frac{j\omega}{\omega_n} + 1 \right]^q$$

Magnitude and Phase:

$$|G(j\omega)|_{dB} = q \cdot 10 \log \left[\left(1 - \frac{\omega^2}{\omega_n^2} \right)^2 + \left(2\zeta \frac{\omega}{\omega_n} \right)^2 \right]$$

$$\angle G(j\omega) = q \cdot \tan^{-1} \left(\frac{2\zeta\omega / \omega_n}{1 - \omega^2 / \omega_n^2} \right)$$

Asymptotic behavior:

$$|G(j\omega)|_{dB} \xrightarrow{\omega \ll \omega_n} 0$$

$$\angle G(j\omega) \xrightarrow{\omega \ll \omega_n} 0^\circ$$

$$|G(j\omega)|_{dB} \xrightarrow{\omega \gg \omega_n} -2q \cdot \omega_n |_{dB} + q \cdot 40 \log \omega$$

$$\angle G(j\omega) \xrightarrow{\omega \gg \omega_n} q \cdot 180^\circ$$

General Transfer Function: Complex poles/zeros

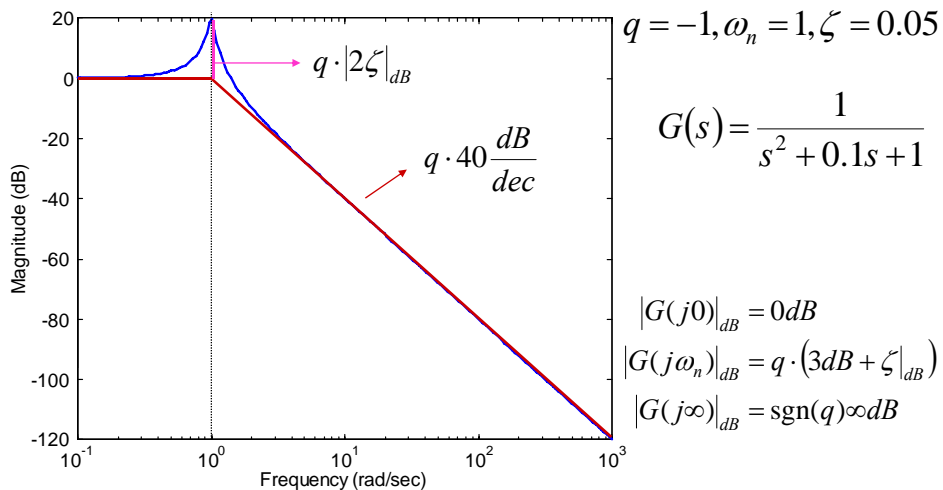

$$|G(j\omega)|_{dB}^{MAX} = |G(j\omega_r)|_{dB} = q \cdot (2\zeta \sqrt{1 - \zeta^2})_{dB} \Leftrightarrow \omega = \omega_r = \frac{\omega_n}{\sqrt{1 - \zeta^2}}$$

General Transfer Function: Complex poles/zeros

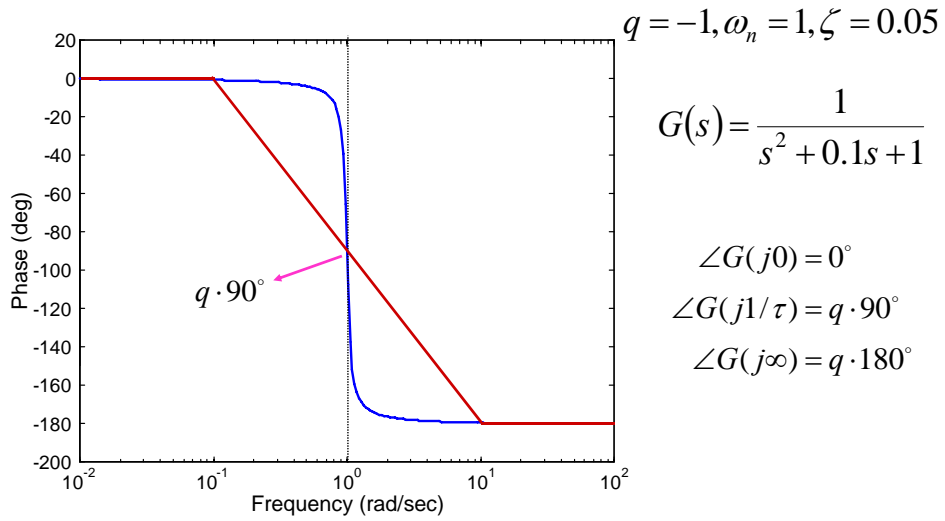

Frequency Response

Example:

$$G(s) = \frac{2000(s + 0.5)}{s(s + 10)(s + 50)}$$

Frequency Response: Poles/Zeros in the RHP

- Same $|G(j\omega)|$.
- The effect on $\angle G(j\omega)$ is opposite than the stable case.

An unstable pole behaves like a stable zero
 An "unstable" zero behaves like a "stable" pole

Example:
$$G(s) = \frac{1}{s-2}$$

This frequency response cannot be found experimentally but can be computed and used for control design.

First order LOW PASS

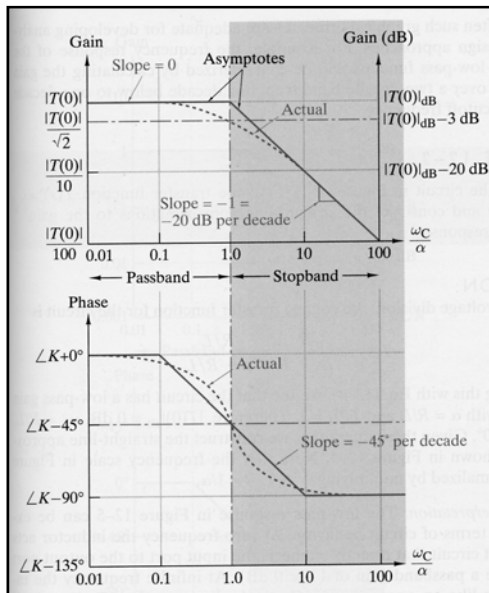

$$T(s) = \frac{K}{s + \alpha}$$

$$T(j\omega) = \frac{K}{j\omega + \alpha}$$

Gain and Phase:

$$|T(j\omega)| = \frac{|K|}{\sqrt{\omega^2 + \alpha^2}}$$

$$\theta(\omega) = \angle K - \tan^{-1}(\omega/\alpha)$$

$$\angle K = \begin{cases} 0 & K > 0 \\ -180^\circ & K < 0 \end{cases}$$

First order LOW PASS

$$|T(j\omega)| = \frac{|K|}{\sqrt{\omega^2 + \alpha^2}}$$

$$\theta(\omega) = \angle K - \tan^{-1}(\omega/\alpha)$$

$$|T(0)| = \frac{|K|}{\alpha}, T(\infty) = 0$$

$$|T(j\alpha)| = \frac{|K|}{\sqrt{\alpha^2 + \alpha^2}} = \frac{|K|/\alpha}{\sqrt{2}} = \frac{T(0)}{\sqrt{2}} \Rightarrow \omega_c = \alpha \quad \text{Cutoff frequency}$$

$$|T(j\omega)| \xrightarrow{\omega \ll \alpha} \frac{|K|}{\alpha} \quad \frac{|K|}{\alpha} = \frac{|K|}{\omega} \Leftrightarrow \omega = \omega_c = \alpha \quad \text{Cutoff frequency}$$

$$|T(j\omega)| \xrightarrow{\omega \gg \alpha} \frac{|K|}{\omega}$$

$$B = \omega_c \quad \text{Bandwidth}$$

First order LOW PASS

$$|T(j\omega)| = \frac{|K|}{\sqrt{\omega^2 + \alpha^2}}$$

$$\theta(\omega) = \angle K - \tan^{-1}(\omega/\alpha)$$

$$\theta(0) = \angle K$$

$$|\theta(\alpha)| = \angle K - \tan^{-1}(1) = \angle K - 45^\circ$$

$$|\theta(\omega)| \xrightarrow{\omega \ll \alpha} \angle K$$

$$|\theta(\omega)| \xrightarrow{\omega \gg \alpha} \angle K - 90^\circ$$

First Order HIGH PASS

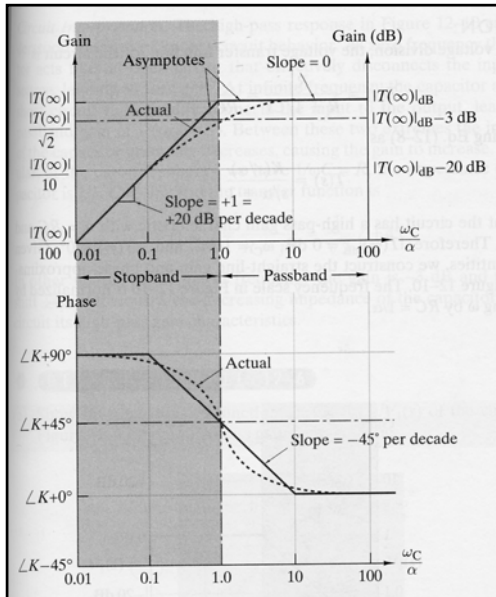

$$T(s) = \frac{Ks}{s + \alpha}$$

↓

$$T(j\omega) = \frac{Kj\omega}{j\omega + \alpha}$$

Gain and Phase:

$$|T(j\omega)| = \frac{|K|\omega}{\sqrt{\omega^2 + \alpha^2}}$$

$$\theta(\omega) = \angle K + 90^\circ - \tan^{-1}(\omega/\alpha)$$

$$\angle K = \begin{cases} 0 & K > 0 \\ -180^\circ & K < 0 \end{cases}$$

Classical Control – Prof. Eugenio Schuster – Lehigh University

155

First order HIGH PASS

$$|T(j\omega)| = \frac{|K|\omega}{\sqrt{\omega^2 + \alpha^2}}$$

$$\theta(\omega) = \angle K + 90^\circ - \tan^{-1}(\omega/\alpha)$$

$$|T(0)| = 0, |T(\infty)| = |K|$$

$$|T(j\alpha)| = \frac{|K|\alpha}{\sqrt{\alpha^2 + \alpha^2}} = \frac{|K|}{\sqrt{2}} = \frac{|T(\infty)|}{\sqrt{2}} \Rightarrow \omega_c = \alpha$$

Cutoff frequency

$$\begin{aligned} |T(j\omega)| &\xrightarrow{\omega \ll \alpha} |K|\omega/\alpha \\ |T(j\omega)| &\xrightarrow{\omega \gg \alpha} |K| \end{aligned} \quad \frac{|K|\omega}{\alpha} = |K| \Leftrightarrow \omega = \omega_c = \alpha$$

Cutoff frequency

$$B = \infty$$

Bandwith

Classical Control – Prof. Eugenio Schuster – Lehigh University

156

First order HIGH PASS

$$|T(j\omega)| = \frac{|K|\omega}{\sqrt{\omega^2 + \alpha^2}}$$

$$\theta(\omega) = \angle K + 90^\circ - \tan^{-1}(\omega/\alpha)$$

$$\theta(0) = \angle K + 90^\circ$$

$$|\theta(\alpha)| = \angle K + 90^\circ - \tan^{-1}(1) = \angle K + 45^\circ$$

$$|\theta(\omega)| \xrightarrow{\omega \ll \alpha} \angle K + 90^\circ$$

$$|\theta(\omega)| \xrightarrow{\omega \gg \alpha} \angle K + 90^\circ - \tan^{-1}(\infty) = \angle K$$

First Order BANDPASS

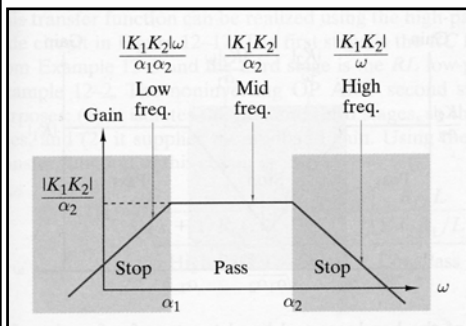

$$T(s) = T_1(s) \times T_2(s) = \left(\frac{K_1 s}{s + \alpha_1} \right) \left(\frac{K_2}{s + \alpha_2} \right)$$

↓

$$T(j\omega) = \left(\frac{K_1 j\omega}{j\omega + \alpha_1} \right) \left(\frac{K_2}{j\omega + \alpha_2} \right)$$

$$|T(j\omega)| = \left(\frac{|K_1| \omega}{\sqrt{\omega^2 + \alpha_1^2}} \right) \left(\frac{|K_2|}{\sqrt{\omega^2 + \alpha_2^2}} \right)$$

$$|T(j\omega)| \xrightarrow{\omega \ll \alpha_1 \ll \alpha_2} \frac{|K_1| |K_2| \omega}{\alpha_1 \alpha_2}$$

$$|T(j\omega)| \xrightarrow{\alpha_1 \ll \omega \ll \alpha_2} \frac{|K_1| |K_2|}{\alpha_2}$$

$$|T(j\omega)| \xrightarrow{\alpha_1 \ll \alpha_2 \ll \omega} \frac{|K_1| |K_2|}{\omega}$$

$$\frac{|K_1| |K_2| \omega}{\alpha_1 \alpha_2} = \frac{|K_1| |K_2|}{\alpha_2} \Rightarrow \omega = \omega_c^H = \alpha_1$$

$$\frac{|K_1| |K_2|}{\alpha_2} = \frac{|K_1| |K_2|}{\omega} \Rightarrow \omega = \omega_c^L = \alpha_2$$

$$B = \omega_c^L - \omega_c^H = \alpha_2 - \alpha_1 \quad \text{Passband}$$

First Order BANDSTOP

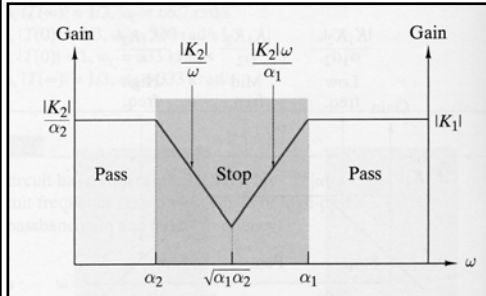

$$|T(j\omega)| = \left(\frac{|K_1|\omega}{\sqrt{\omega^2 + \alpha_1^2}} \right) + \left(\frac{|K_2|}{\sqrt{\omega^2 + \alpha_2^2}} \right)$$

$$|T(j\omega)| \xrightarrow{\omega \ll \alpha_2 \ll \alpha_1} \frac{|K_2|}{\alpha_2}$$

$$|T(j\omega)| \xrightarrow{\alpha_2 \ll \alpha_1 \ll \omega} |K_1|$$

$$\frac{|K_2|}{\alpha_2} = |K_1|$$

$$|T(j\omega)| \xrightarrow{\alpha_2 < \omega} \frac{|K_2|}{\omega}$$

$$|T(j\omega)| \xrightarrow{\omega < \alpha_1} \frac{|K_1|\omega}{\alpha_1}$$

$$\Rightarrow \frac{|K_2|}{\omega} = \frac{|K_1|\omega}{\alpha_1} \Rightarrow \omega = \sqrt{\frac{\alpha_1 |K_2|}{|K_1|}} = \sqrt{\alpha_1 \alpha_2}$$

$$B = \alpha_1 - \alpha_2 \quad \text{Bandstop}$$

Second Order BANDPASS

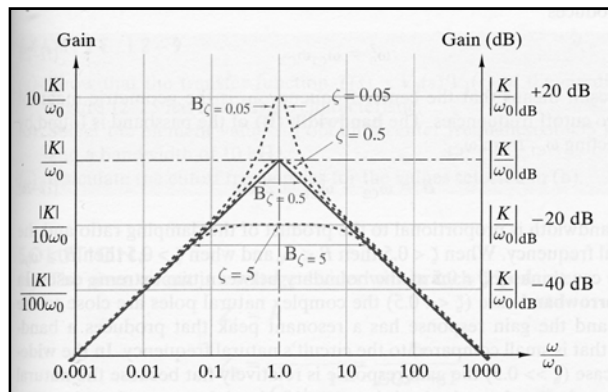

$$T(s) = \frac{Ks}{s^2 + 2\zeta\omega_0 s + \omega_0^2} \Rightarrow T(j\omega) = \frac{Kj\omega}{-\omega^2 + 2\zeta\omega_0 j\omega + \omega_0^2}$$

ω_0 : Natural Frequency

ζ : Damping Ratio

Second Order BANDPASS

$$T(s) = \frac{Ks}{s^2 + 2\zeta\omega_o s + \omega_o^2} \Rightarrow T(j\omega) = \frac{Kj\omega}{-\omega^2 + 2\zeta\omega_o j\omega + \omega_o^2}$$

$$T(j\omega) \xrightarrow{\omega \ll \omega_o} = \frac{|K|\omega}{\omega_o^2}$$

$$T(j\omega) \xrightarrow{\omega \gg \omega_o} = \frac{|K|}{\omega}$$

$$\frac{|K|\omega}{\omega_o^2} = \frac{|K|}{\omega} \Rightarrow \omega = \omega_o$$

$$T(j\omega) = \frac{K/\omega_o}{2\zeta + j\left(\frac{\omega}{\omega_o} - \frac{\omega_o}{\omega}\right)} \xrightarrow{\omega=\omega_o} |T(j\omega)|_{MAX} = \frac{K/\omega_o}{2\zeta}$$

Second Order BANDPASS

$$T(j\omega) = \frac{K/\omega_o}{2\zeta + j\left(\frac{\omega}{\omega_o} - \frac{\omega_o}{\omega}\right)} \xrightarrow{\omega=\omega_o} |T(j\omega)|_{MAX} = \frac{K/\omega_o}{2\zeta}$$

$$T(j\omega) \Big|_{\frac{\omega}{\omega_o} - \frac{\omega_o}{\omega} = \pm 2\zeta} = \frac{K/\omega_o}{2\zeta + j2\zeta} \Rightarrow |T(j\omega)| = \frac{K/\omega_o}{\sqrt{2}} = \frac{|T(j\omega)|_{MAX}}{\sqrt{2}}$$

The roots of $\frac{\omega}{\omega_o} - \frac{\omega_o}{\omega} = \pm 2\zeta$ are the cutoff frequencies!!!

$$\omega_{C1} = \omega_o \left(-\zeta + \sqrt{1 + \zeta^2} \right)$$

$$\omega_{C2} = \omega_o \left(+\zeta + \sqrt{1 + \zeta^2} \right)$$

$$\Rightarrow \omega_o^2 = \omega_{C1}\omega_{C2} \quad \text{Center Frequency}$$

$$B = \omega_{C2} - \omega_{C1} = 2\zeta \quad \text{Bandwidth}$$

Second Order LOWPASS

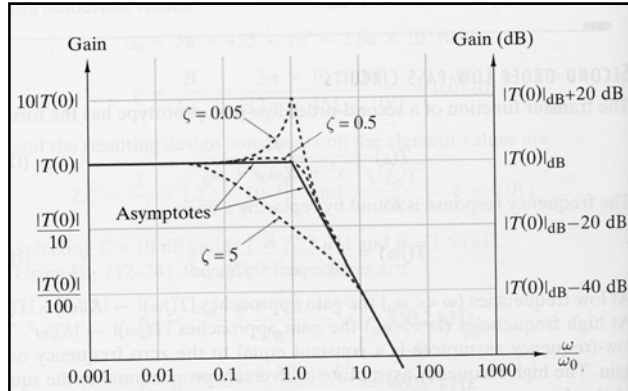

$$T(s) = \frac{K}{s^2 + 2\zeta\omega_o s + \omega_o^2} \Rightarrow T(j\omega) = \frac{K}{-\omega^2 + 2\zeta\omega_o j\omega + \omega_o^2}$$

ω_o : Natural Frequency

ζ : Damping Ratio

Second Order LOWPASS

$$T(s) = \frac{K}{s^2 + 2\zeta\omega_o s + \omega_o^2} \Rightarrow T(j\omega) = \frac{K}{-\omega^2 + 2\zeta\omega_o j\omega + \omega_o^2}$$

$$T(j\omega) \xrightarrow{\omega \ll \omega_o} \frac{|K|}{\omega_o^2} = |T(0)|$$

$$T(j\omega) \xrightarrow{\omega \gg \omega_o} \frac{|K|}{\omega^2}$$

$$\frac{|K|}{\omega_o^2} = \frac{|K|}{\omega^2} \Rightarrow \omega = \omega_o$$

$$T(j\omega_o) = \frac{K / \omega_o}{2\zeta} = \frac{|T(0)|}{2\zeta}$$

$$|T(j\omega)|_{MAX} = \frac{|T(0)|}{2\zeta\sqrt{1-\zeta^2}} \Leftrightarrow \omega = \omega_{MAX} = \omega_o\sqrt{1-\zeta^2}$$

Second Order HIGHPASS

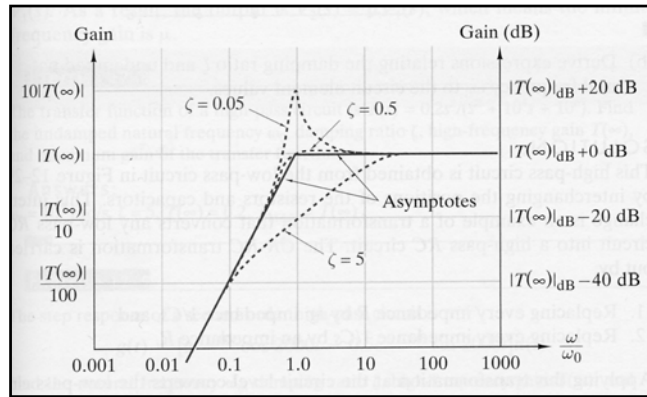

$$T(s) = \frac{Ks^2}{s^2 + 2\zeta\omega_o s + \omega_o^2} \Rightarrow T(j\omega) = \frac{-K\omega^2}{-\omega^2 + 2\zeta\omega_o j\omega + \omega_o^2}$$

ω_o : Natural Frequency

ζ : Damping Ratio

Second Order HIGHPASS

$$T(s) = \frac{Ks^2}{s^2 + 2\zeta\omega_o s + \omega_o^2} \Rightarrow T(j\omega) = \frac{-K\omega^2}{-\omega^2 + 2\zeta\omega_o j\omega + \omega_o^2}$$

$$T(j\omega) \xrightarrow{\omega \ll \omega_o} -\frac{|K|\omega^2}{\omega_o^2} \qquad \frac{|K|\omega^2}{\omega_o^2} = |K| \Rightarrow \omega = \omega_o$$

$$T(j\omega) \xrightarrow{\omega \gg \omega_o} = |K| = |T(\infty)|$$

$$|T(j\omega_o)| = \frac{|K|}{2\zeta} = \frac{|T(\infty)|}{2\zeta}$$

$$|T(j\omega)|_{MAX} = \frac{|T(\infty)|}{2\zeta\sqrt{1-\zeta^2}} \Leftrightarrow \omega = \omega_{MAX} = \frac{\omega_o}{\sqrt{1-\zeta^2}}$$

Frequency Response

$$u(t) = A \cos(\omega t + \phi) \rightarrow \boxed{G(s)} \rightarrow y_{ss} = |G(j\omega)| A \cos(\omega t + \phi + \angle G(j\omega))$$

Stable Transfer Function

$$G(j\omega) = |G(j\omega)| e^{j\angle G(j\omega)} \quad \text{BODE plots}$$

$$G(j\omega) = \text{Re}\{G(j\omega)\} + j \text{Im}\{G(j\omega)\} \quad \text{NYQUIST plots}$$

Frequency Response

$$G(j\omega) = \text{Re}\{G(j\omega)\} + j \text{Im}\{G(j\omega)\} = |G(j\omega)| e^{j\angle G(j\omega)}$$

How are the Bode and Nyquist plots related?

They are two way to represent the same information

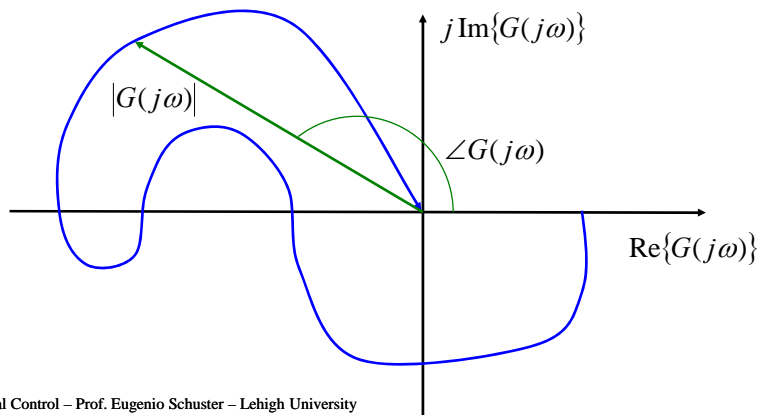

Frequency Response

- Find the steady state output for $v_1(t) = A \cos(\omega t + \phi)$

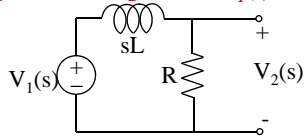

- Compute the s-domain transfer function $T(s)$

– Voltage divider $T(s) = \frac{R}{sL + R}$

- Compute the frequency response

$$|T(j\omega)| = \frac{R}{\sqrt{R^2 + (\omega L)^2}}, \quad \angle T(j\omega) = -\tan^{-1}\left(\frac{\omega L}{R}\right)$$

- Compute the steady state output

$$v_{2SS}(t) = \frac{AR}{\sqrt{R^2 + (\omega L)^2}} \cos\left[\omega t + \phi - \tan^{-1}(\omega L / R)\right]$$

Frequency Response - Bode Plots

- Log-log plot of $\text{mag}(T)$, log-linear plot of $\text{arg}(T)$ versus ω

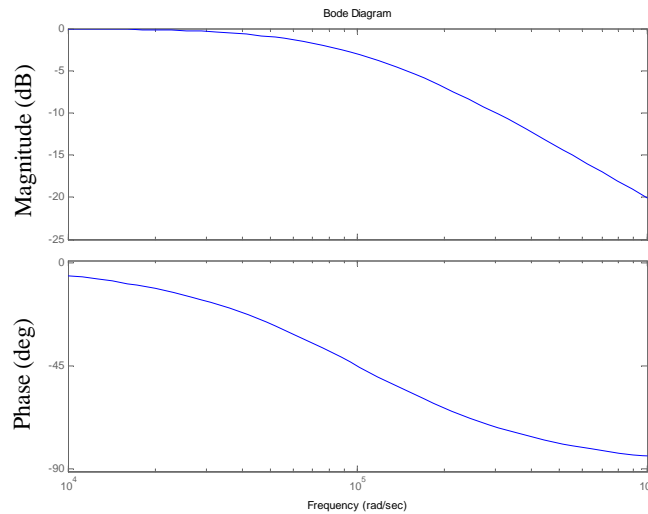

$$G(s) = \frac{10}{s + 10}$$

$R/L = 10$

$[\omega] = \text{rad/sec}, \quad \omega = 2\pi f, \quad [f] = \text{Hz}$

Frequency Response – Nyquist Plots

$$T(j\omega) = \frac{R}{R + j\omega L} = \frac{R}{R + j\omega L} \frac{R - j\omega L}{R - j\omega L} = \frac{R^2 - j\omega RL}{R^2 + \omega^2 L^2}$$

$$|T(j\omega)| = \frac{R}{\sqrt{R^2 + (\omega L)^2}}, \quad \angle T(j\omega) = -\tan^{-1}\left(\frac{\omega L}{R}\right)$$

$$\operatorname{Re}\{T(j\omega)\} = \frac{R^2}{R^2 + \omega^2 L^2}, \quad \operatorname{Im}\{T(j\omega)\} = -\frac{\omega RL}{R^2 + \omega^2 L^2}$$

1- $\omega \rightarrow 0: |T(j\omega)| \rightarrow 1, \quad \angle T(j\omega) \rightarrow 0 \quad T(j\omega) = 1$

2- $\omega \rightarrow \infty: |T(j\omega)| \rightarrow 0, \quad \angle T(j\omega) \rightarrow -90^\circ \quad T(j\omega) \xrightarrow{\omega \rightarrow \infty} -j \frac{R}{\omega L} \xrightarrow{\omega \rightarrow \infty} 0$

3- $\operatorname{Re}\{T(j\omega)\} = 0 \Leftrightarrow \omega = \infty$

4- $\operatorname{Im}\{T(j\omega)\} = 0 \Leftrightarrow \omega = 0, \omega = \infty$

Frequency Response - Nyquist Plots

$\operatorname{Im}\{G(j\omega)\}$ vs. $\operatorname{Re}\{G(j\omega)\}$

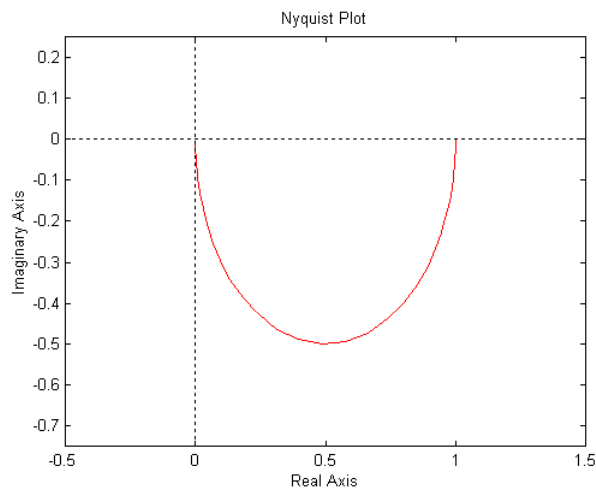

$$G(s) = \frac{10}{s + 10}$$

$$R/L = 10$$

Nyquist Diagrams

General procedure for sketching Nyquist Diagrams:

- Find $G(j0)$
- Find $G(j\infty)$
- Find ω^* such that $\text{Re}\{G(j\omega^*)\}=0$; $\text{Im}\{G(j\omega^*)\}$ is the intersection with the imaginary axis.
- Find ω^* such that $\text{Im}\{G(j\omega^*)\}=0$; $\text{Re}\{G(j\omega^*)\}$ is the intersection with the real axis.
- Connect the points

Frequency Response - Nyquist Plots

Example:

$$G(s) = \frac{1}{s(s+1)^2}$$

$$G(j\omega) = \frac{1}{j\omega(j\omega+1)^2} = \frac{1}{j\omega(j\omega+1)^2} \frac{(-j\omega)(1-j\omega)^2}{(-j\omega)(1-j\omega)^2} = \frac{-2\omega + j(\omega^2 - 1)}{\omega(\omega^2 + 1)^2}$$

1- $\omega \rightarrow 0: G(j\omega) = -2 - j\infty$

2- $\omega \rightarrow \infty: G(j\omega) \xrightarrow{\omega \rightarrow \infty} j \frac{1}{\omega^3} \xrightarrow{\omega \rightarrow \infty} 0$

3- $\text{Re}\{G(j\omega)\} = 0 \Leftrightarrow \omega = \infty$

4- $\text{Im}\{G(j\omega)\} = 0 \Leftrightarrow \omega = 1, \omega = \infty \quad \text{Re}\{G(j1)\} = -\frac{1}{2}$

Frequency Response - Nyquist Plots

Example:

$$G(s) = \frac{1}{s(s+1)^2}$$

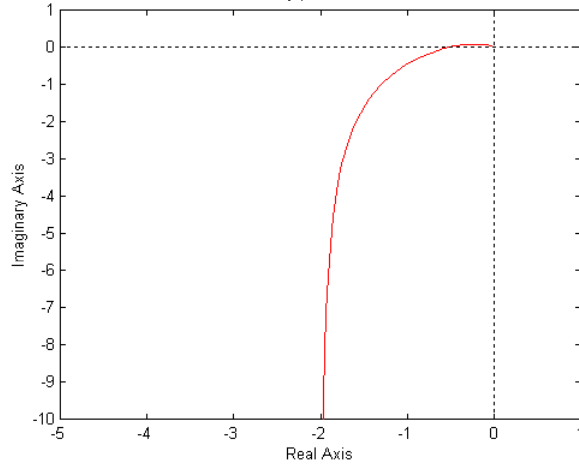

Classical Control – Prof. Eugenio Schuster – Lehigh University

175

Nyquist Plots based on Bode Plots

Bode Diagrams

$$G(s) = \frac{1}{s(s+1)^2}$$

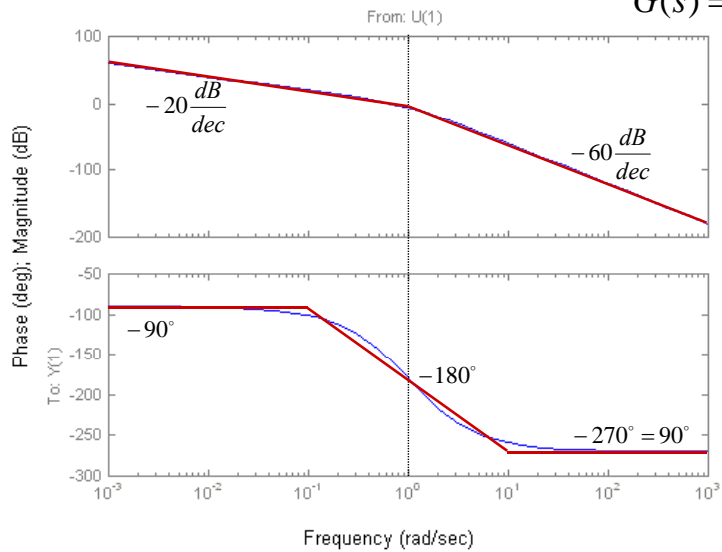

Classical Control – Prof. Eugenio Schuster – Lehigh University

176

Nyquist Stability Criterion

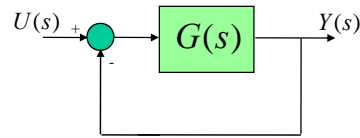

When is this transfer function Stable?

NYQUIST: The closed loop is asymptotically stable if the number of counterclockwise encirclements of the point $(-1+j0)$ that the Nyquist curve of $G(j\omega)$ is equal to the number of poles of $G(s)$ with positive real parts (unstable poles)

Corollary: If the open-loop system $G(s)$ is stable, then the closed-loop system is also stable provided $G(s)$ makes no encirclement of the point $(-1+j0)$.

Nyquist Stability Criterion

$$G(s) = \frac{1}{s^4 + 2s^3 + 3s^2 + 3s + 1}$$

$$G(s) = \frac{1}{s^4 + 5s^3 + 3s^2 + 3s + 1}$$

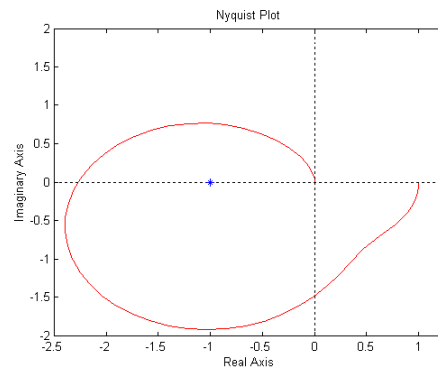
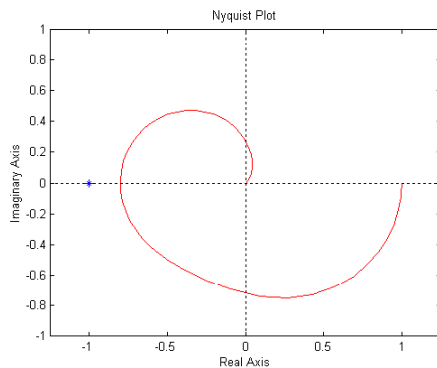

Nyquist Stability Criterion

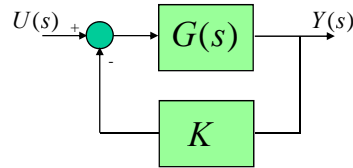

When is this transfer function Stable?

NYQUIST: The closed loop is asymptotically stable if the number of counterclockwise encirclements of the point $(-1/K+j0)$ that the Nyquist curve of $G(j\omega)$ is equal to the number of poles of $G(s)$ with positive real parts (unstable poles)

Neutral Stability

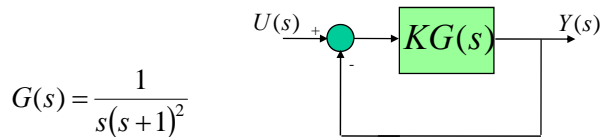

$$G(s) = \frac{1}{s(s+1)^2}$$

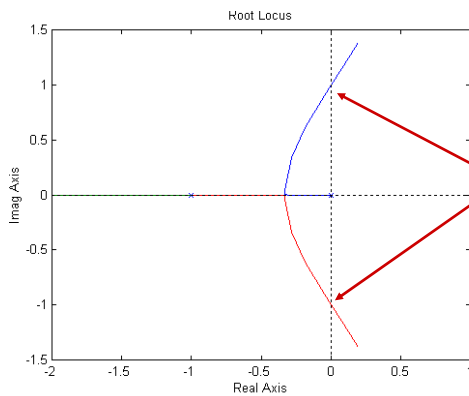

Root locus condition:

$$|KG(s)|=1, \quad \angle G(s) = -180^\circ$$

At points of neutral stability
RL condition hold for $s=j\omega$

$$|KG(j\omega)|=1, \quad \angle G(j\omega) = -180^\circ$$

Stability: At $\angle G(j\omega) = -180^\circ$

$|KG(j\omega)| < 1$ If $\uparrow K$ leads to instability

$|KG(j\omega)| > 1$ If $\downarrow K$ leads to instability

Stability Margins

The **GAIN MARGIN (GM)** is the factor by which the gain can be raised before instability results.

$$|GM| < 1 \left(|GM|_{dB} < 0 \right) \Rightarrow \text{UNSTABLE SYSTEM}$$

GM is equal to $1/|KG(j\omega)|$ ($-|KG(j\omega)|_{dB}$) at the frequency where $\angle G(j\omega) = -180^\circ$.

The **PHASE MARGIN (PM)** is the value by which the phase can be raised before instability results.

$$PM < 0 \Rightarrow \text{UNSTABLE SYSTEM}$$

PM is the amount by which the phase of $G(j\omega)$ exceeds -180° when $|KG(j\omega)| = 1$ ($|KG(j\omega)|_{dB} = 0$)

Stability Margins

$$G(s) = \frac{1}{s(s+1)^2}$$

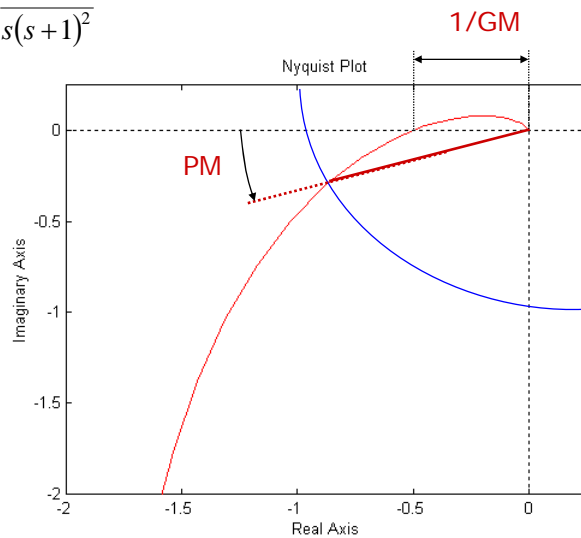

Stability Margins

Bode Diagrams

$$G(s) = \frac{1}{s(s+1)^2}$$

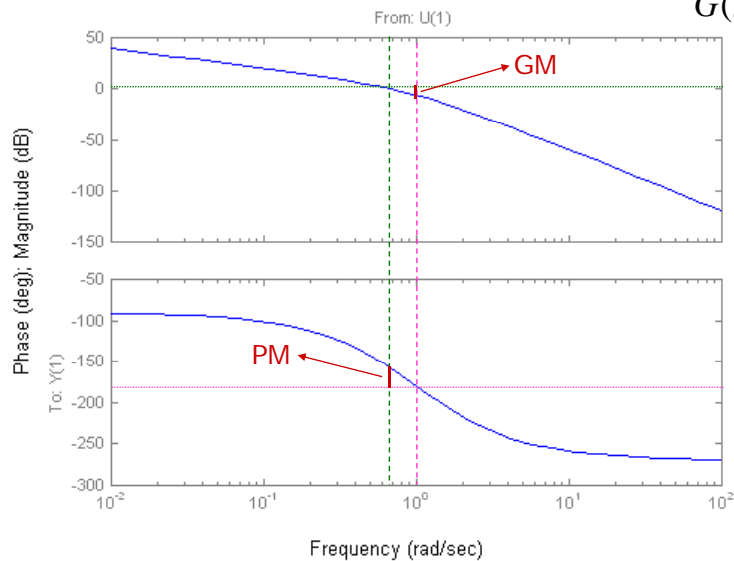

Classical Control – Prof. Eugenio Schuster – Lehigh University

183

Specifications in the Frequency Domain

1. The **crossover frequency** ω_c , which determines bandwidth ω_{BW} , rise time t_r and settling time t_s .
2. The **phase margin** PM , which determines the damping coefficient ζ and the overshoot M_p .
3. The **low-frequency gain**, which determines the steady-state error characteristics.

Classical Control – Prof. Eugenio Schuster – Lehigh University

184

Specifications in the Frequency Domain

The phase and the magnitude are NOT independent!

Bode's Gain-Phase relationship:

$$\angle G(j\omega_o) = \frac{1}{\pi} \int_{-\infty}^{+\infty} \frac{dM}{du} W(u) du$$

$$M = \ln|G(j\omega)|$$

$$u = \ln(\omega / \omega_o)$$

$$W(u) = \ln(\coth|u|/2)$$

Specifications in the Frequency Domain

The crossover frequency: $\omega_c \leq \omega_{BW} \leq 2\omega_c$

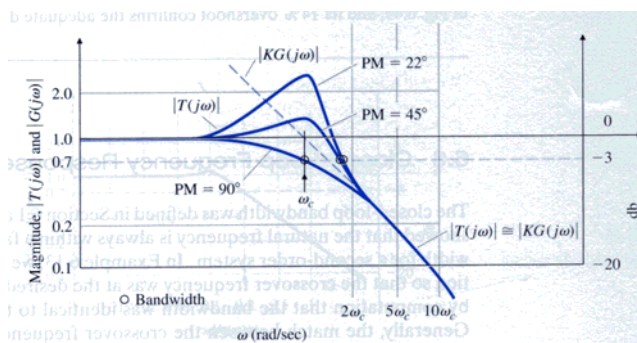

Specifications in the Frequency Domain

The Phase Margin: PM vs. M_p

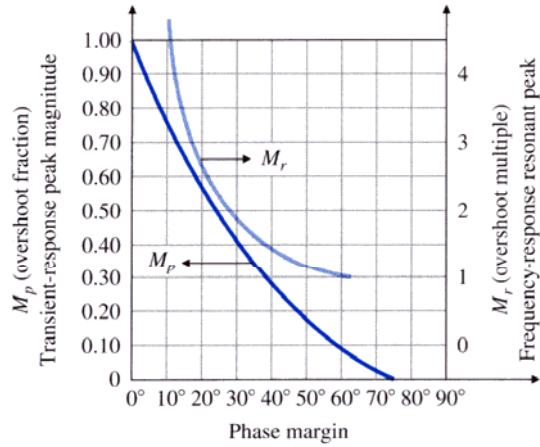

Specifications in the Frequency Domain

The Phase Margin: PM vs. ζ $\zeta \cong \frac{PM}{100}$

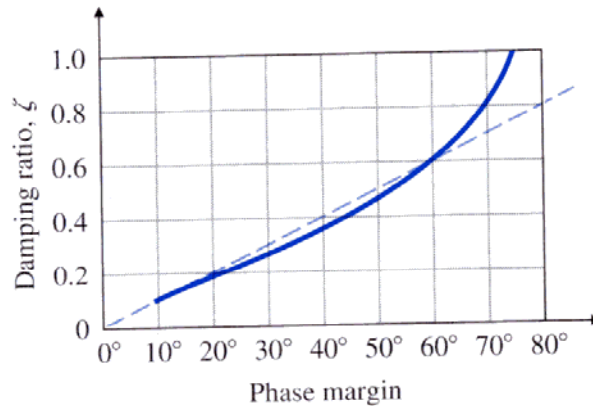

Frequency Response – Phase Lead Compensators

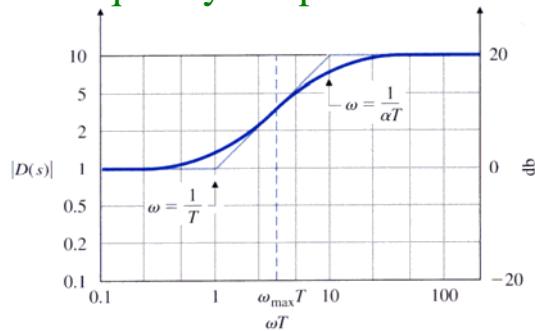

$$D(s) = \frac{Ts + 1}{\alpha Ts + 1}, \quad \alpha < 1$$

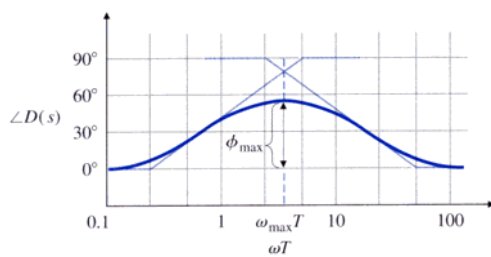

$$\alpha = \frac{1 - \sin \phi_{MAX}}{1 + \sin \phi_{MAX}}$$

$$\log \omega_{MAX} = \frac{1}{2} \left[\log \left(\frac{1}{T} \right) + \log \left(\frac{1}{\alpha T} \right) \right]$$

Classical Control – Prof. Eugenio Schuster – Lehigh University

189

Frequency Response – Phase Lead Compensators

1. Determine the open-loop gain K to satisfy error or bandwidth requirements:
 - To meet error requirement, pick K to satisfy error constants (K_p , K_v , K_a) so that e_{ss} specification is met.
 - To meet bandwidth requirement, pick K so that the open-loop crossover frequency is a factor of two below the desired closed-loop bandwidth.
2. Determine the needed phase lead $\rightarrow \alpha$ based on the PM specification.
3. Pick ω_{MAX} to be at the crossover frequency.
4. Determine the zero and pole of the compensator.
5. Draw the compensated frequency response and check PM.
6. Iterate on the design

Classical Control – Prof. Eugenio Schuster – Lehigh University

190

Frequency Response – Phase Lag Compensators

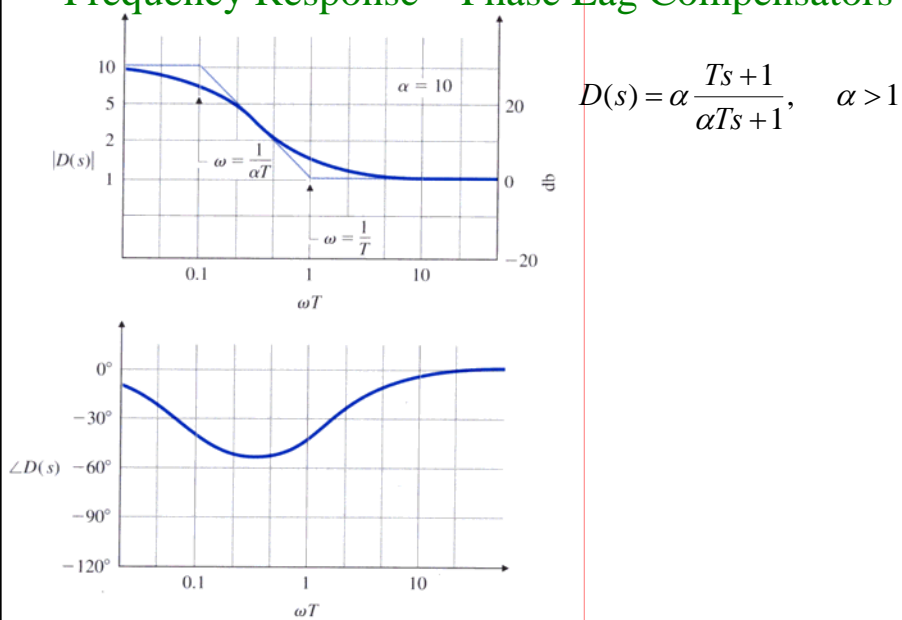

Classical Control – Prof. Eugenio Schuster – Lehigh University

191

Frequency Response – Phase Lag Compensators

1. Determine the open-loop gain K that will meet the PM requirement without compensation.
2. Draw the Bode plot of the uncompensated system with crossover frequency from step 1 and evaluate the low-frequency gain.
3. Determine α to meet the low frequency gain error requirement.
4. Choose the corner frequency $\omega = 1/T$ (the zero of the compensator) to be one decade below the new crossover frequency ω_c .
5. The other corner frequency (the pole of the compensator) is then $\omega = 1/\alpha T$.
6. Iterate on the design

Classical Control – Prof. Eugenio Schuster – Lehigh University

192